

TS/ISO Registered



ADRIAN STEEL®

Cargo Management Solutions for Commercial Vehicles

COMMERCIAL TRUCK EQUIPMENT

2008



Expect More. Get More!



From our beginning in 1953 as a small structural steel warehouse with four employees, Adrian Steel Company has grown to become a leader in the van and truck equipment industry. Located in Adrian, Michigan, our manufacturing facility now encompasses 166,900 square feet with over 300 employees. Adrian Steel is committed to providing quality products highlighted by constant innovation.



Those values instilled a team effort to provide customers with value-added products and services that have become the standard of our industry.



Cargo Management Solutions

We have developed a comprehensive network for handling all your vehicle needs, no matter how many units you need or where your vehicles will be put to work. You cannot always plan when vehicles will need to be replaced. That's why we have developed a system to get your vehicles upfitted no matter where

Adrian Steel's attention to detail and customers is thorough, it began through the corporate values instilled by founder Bob Westfall, University of Michigan All-American and Detroit Lion All-Pro football standout.



Factory Installation

Adrian Steel offers the most comprehensive factory installation program in the industry. With our factory ship-thru program, your vehicles are upfitted before they are shipped to your dealer. Factory ship-thru programs are available through GM, Ford, and Dodge. A transportation code option would have your vehicles shipped from the assembly plant to one of our upfitting facilities. After being upfitted to your specifications, your vehicles are placed back into the manufacturer's traffic system for final delivery to your dealer. Benefits of the factory ship-thru program include savings on transportation costs, professional installation, standardized pricing on equipment and installation, and a service-ready vehicle upon delivery to your dealer. For more information call Adrian Steel at 1-800-677-2726 or e-mail info@adriansteel.com.

you need to get them done: at the factory, out of dealer stock, at your place of business, or through a bailment pool.

Local Installation

More than 300 independent truck equipment distributors nationwide sell and service Adrian Steel products. Our distributors work with you to provide products and installations on vehicles from local dealer stock. They also provide a full range of other truck equipment products and services. Many of our distributors also provide mobile on-site installation of equipment at dealerships or at your place of business. And when installed by an authorized Adrian Steel distributor or factory installation facility, all Adrian Steel products are warranted for 3 years or 36,000 miles! Click here to find your local Adrian Steel distributor.

Table of contents

- 3 Toolbox features
- 4 Toolbox chart
- 5 Single lid boxes
- 7 Double lid boxes
- 9 Side boxes
- 10 Stow-All
- 11 Underbody boxes
- 13 Full size Load Runner
- 14 Mid size Load Runner
- 15 LoadFlex
- 16 Load Runner accessories
- 17 Service body Load Runner
- 19 Interior packages
- 21 Grip Lock racks



Are you in the market for a new work truck?



Upfit your Chevrolet or GMC pickup with Adrian Steel Equipment for little or no extra charge through the GM Business Choice Program "Option A"*.



Get cash back from Ford on Adrian Steel Equipment through the Ford Commercial Connection Program*.

*Program not available in all areas. Consult your dealer for complete details. For additional information give us a call at 1-800-677-2726. GM is a registered trademark of the General Motors Company. Ford is a registered Trademark of the Ford Motor Company.

More value, more security, more convenience!

More convenience: Now all Adrian Steel aluminum boxes have new and improved push button locks. We have cycle tested our design over 25,000 times ensuring years of trouble free operation.

More security: All Adrian Steel toolboxes now have new and improved anti-intrusion striker securing the toolbox lid, keeping your contents secure.

More value: An improved toolbox tray that is removable and stays on track. Get more with Adrian Steel toolboxes.

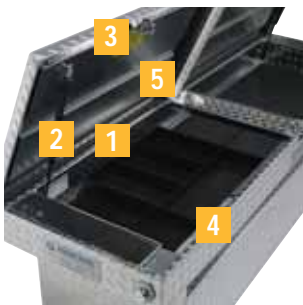

1. Bulb Weather Seal
2. Heavy-duty Gas Struts
3. Intrusion Resistant
4. "U"-Channel Edge
5. Double Reinforced Lid



1. Aluminum Box Lip
2. Mounting Bracket
3. Bed Rail



1. Dome Style Lid
2. Push Button With Lock
3. Rotary Latches
4. Lock & Linkage Guards
5. Divided Plastic Tray

Construction: Fully welded construction of both box body and lid create the strength and rigidity to contain heavy tool loads under rugged conditions.

Stronger Box: Heavy-duty .080" diamond tread aluminum lid where you need it. Rugged .063" diamond tread aluminum box carries parts and tools with ease.

Dome Lids: Feature an extra 45° bend and double channel reinforcement. These add strength and stiffness to the lid, prevent warping and assure snug lid closure.

Weather Secure: Reinforced "U"-channel edge adds structural strength to box and more lid seating surface. Bulb weather seal protects contents against dirt and water infiltration.

Easy Opening: Push button rotary latches open the lids conveniently when your hands are full, while providing increased security when locked. Heavy-duty gas struts assist in lid operation, and provide years of maintenance free operation. Single lid cross boxes have interconnected latches for easy,

one hand operation from either side of truck. A linkage guard protects against linkage damage...no bending, no jamming.

Double Sided Keys: For quicker and easier access to secured toolbox contents.

Inside... designed with you in mind: plastic trays are accessible from both sides of truck providing convenient storage for smaller items. Wider box design gives you increased cargo capacity. Boxes include rubber liner for box bottom.

Additionally: Adrian Steel provides a closed cell foam tape with an adhesive back for the underside of the toolbox overhang to protect pickup truck bed rail. It's an example of the thought that goes into all tool hauling and organizing systems designed and built by Adrian Steel. Find out for yourself. Equip your working truck with tough working aluminum tool boxes by Adrian Steel.

Application Chart

TOOLBOX/VEHICLE

Adrian Steel Aluminum toolboxes are designed to fit most late model pickup trucks.

To ensure proper fit and finish please consult our truck application chart. See pages 5-9 for toolbox dimensions.

Truck Model	Crossboxes Single/Double Lid										Side Boxes			
	AD100/AD200	AD101/AD201	AD101-2/AD201-2	AD101-3/AD201-3	AD150/AD250	AD151	AD160/AD260	AD170/AD270	AD180/AD280	AD190/AD290	AD120/AD220	AD302	AD303	AD350
FORD TRUCKS														
RANGER SB					■									
RANGER LB					■	■								■
RANGER SUPER CAB SB					■									
RANGER SUPER CAB LB					■	■							■	
EXPLORER SPORT-TRAC											■			
F-150 SB	■													
F-150 LB	■	■										■		
F-150 SUPER CAB SB	■													■
F-150 SUPER CAB LB		■										■		
F-150 SPORTSIDE										■				
F-150 CREW-CAB 4-DOOR	■												■	
F-250 SUPER-DUTY LB			■									■		
F-250 SUPER-DUTY SUPER CAB & CREW CAB SB			■										■	
F-250 SUPER-DUTY SUPER CAB & CREW CAB LB			■									■		
F-350 SUPER-DUTY DUALY SB			■										■	
F-350 SUPER-DUTY DUALY LB			■									■		
CHEVROLET/GMC														
COLORADO/CANYON/S-10/S-15 SB							■							
COLORADO/CANYON/S-10/S-15 LB							■							■
COLORADO/CANYON/S-10/S-15 4-DOOR											■			
1500 SB	■													■
1500 LB	■	■										■		
1500 SPORTSIDE								■						
2500 REGULAR & HD SB	■	■												■
2500 REGULAR & HD LB	■	■										■		
3500 HEAVY-DUTY DUALY LB	■	■										■		
DODGE TRUCKS														
AD100/AD200	AD101/AD201	AD101-2/AD201-2	AD101-3/AD201-3	AD150/AD250	AD151	AD160/AD260	AD170/AD270	AD180/AD280	AD190/AD290	AD120/AD220	AD302	AD303	AD350	
DAKOTA SB						■								
DAKOTA 4-DOOR										■				
RAM 1500 SB	■			■									■	
RAM 1500 LB	■	■										■		
RAM 1500 QUAD-CAB SB	■			■									■	
RAM 1500 QUAD-CAB LB	■			■								■		
RAM 2500 SB				■									■	
RAM 2500 LB	■	■										■		
RAM 2500 QUAD-CAB SB				■									■	
RAM 2500 QUAD-CAB LB	■			■								■		
RAM 3500 DUALY LB	■	■										■		
NISSAN TRUCKS														
AD100/AD200	AD101/AD201	AD101-2/AD201-2	AD101-3/AD201-3	AD150/AD250	AD151	AD160/AD260	AD170/AD270	AD180/AD280	AD190/AD290	AD120/AD220	AD302	AD303	AD350	
FRONTIER SB*						■				■		■	■	
FRONTIER LB						■				■		■	■	
TITAN SB*									■			■	■	
TITAN LB									■			■	■	
TOYOTA TRUCKS														
AD100/AD200	AD101/AD201	AD101-2/AD201-2	AD101-3/AD201-3	AD150/AD250	AD151	AD160/AD260	AD170/AD270	AD180/AD280	AD190/AD290	AD120/AD220	AD302	AD303	AD350	
TACOMA SB								■						■
TACOMA LB							■						■	■
TACOMA 4-DOOR SB							■			■			■	■
TUNDRA SB 05-06									■				■	■
TUNDRA LB 05-06									■				■	■
TUNDRA SB 07-ON	■	■											■	
TUNDRA LB 07-ON	■	■										■		
MAZDA TRUCKS														
AD100/AD200	AD101/AD201	AD101-2/AD201-2	AD101-3/AD201-3	AD150/AD250	AD151	AD160/AD260	AD170/AD270	AD180/AD280	AD190/AD290	AD120/AD220	AD302	AD303	AD350	
B2500 SB									■				■	
B2500 LB						■						■		
ISUZU TRUCKS														
AD100/AD200	AD101/AD201	AD101-2/AD201-2	AD101-3/AD201-3	AD150/AD250	AD151	AD160/AD260	AD170/AD270	AD180/AD280	AD190/AD290	AD120/AD220	AD302	AD303	AD350	
B2000 SB								■					■	
B2000 LB						■						■		

* Side box not available if cross box is present



Single lid convenience with Adrian Steel Single Lid toolboxes.

Single Lid toolboxes provide a large storage area when long equipment storage is needed. Single Lid toolboxes open or lock from either side of the truck with interconnected push button rotary latches. Linkage guard protects the linkage between latches from getting bent or damaged while loading or unloading your toolbox.

Construction

- A** 3 piece fully welded diamond plate body for strength and leak prevention
- B** Gaskets on all four sides of the lid for additional leak prevention
- C** Heavy Duty gas struts assist in lid operation
- D** Linkage guard protects against linkage damage

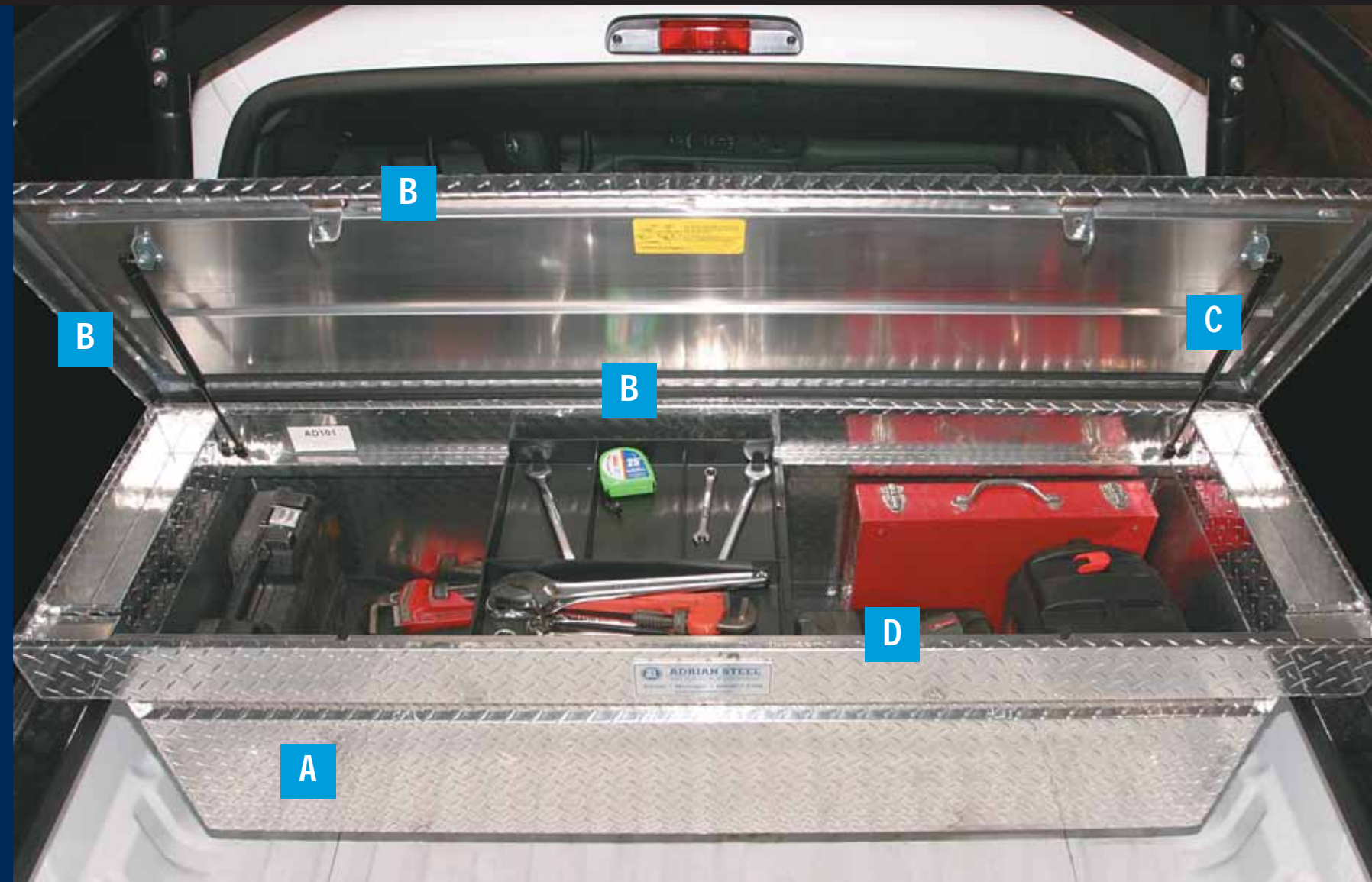

Visibility

Rigid low profile dome lid provides maximum visibility out your rear window.



Easy opening

New and improved automotive push button lock with double bitting lock cylinder.

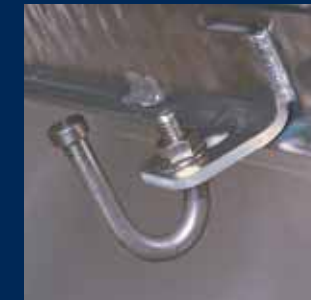

Security

Fully adjustable intrusion resistant striker keeps contents more secure.



No-drill brackets

Secure the box to your truck without drilling while protecting your truck bed rails.

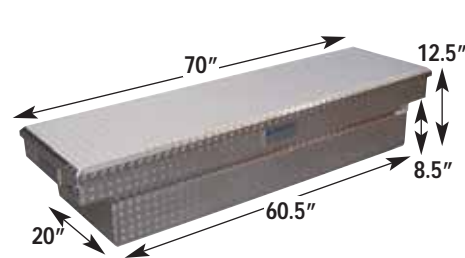

AD100 Fits most late model full size pickups, short and long bed Chevy Silverado, GMC Sierra, Ford F150, Dodge Ram and 2007-on Toyota Tundra

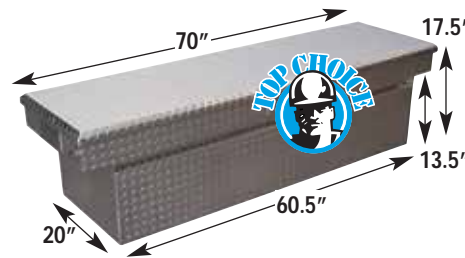

AD101 Fits most late model full size pickups, short and long bed Chevy Silverado, GMC Sierra, Ford F-150, Dodge Ram and 2007-on Toyota Tundra

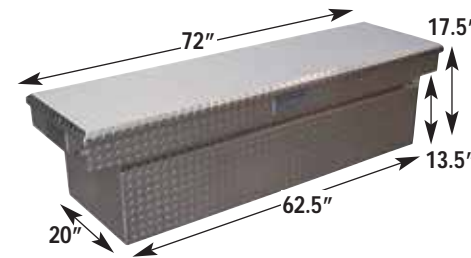

AD101-2 Fits late model Ford Super Duty short bed and long bed pickup trucks

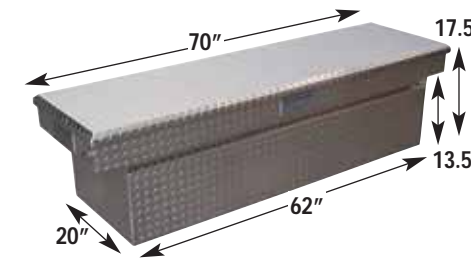

AD101-3 Fits late model Dodge Ram short bed and long bed pickup trucks

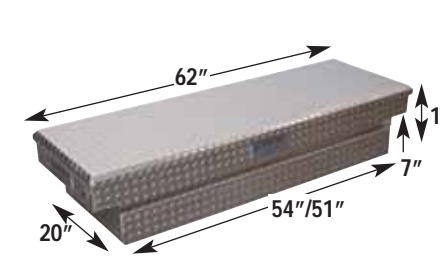

AD120 Fits late model Ford Explorer Sport-Trac, S10 Crew Cab, Chevy Colorado Crew Cab, GMC Canyon Crew Cab, Nissan Frontier, Toyota Tacoma and Dodge Dakota 4-Door

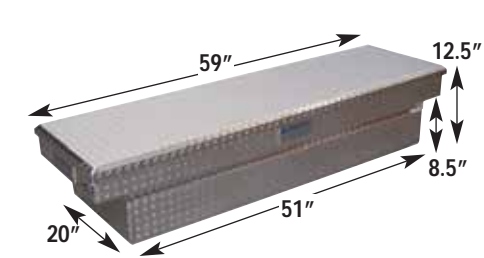

AD150 Fits late model Ford Ranger regular cab and Ranger Super Cab short and long bed pickups

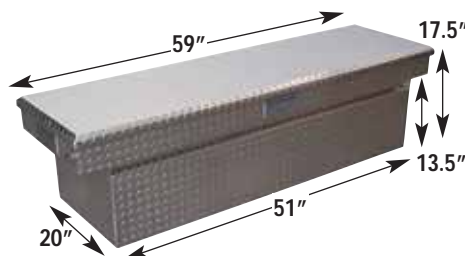

AD151 Fits Ford Ranger Regular cab, and Ranger Super cab long bed pickups

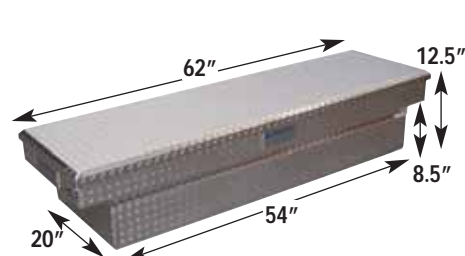

AD160 Fits late model Chevy Colorado, GMC Canyon, Dodge Dakota, Nissan Frontier and Toyota Tacoma short bed and long bed pickups

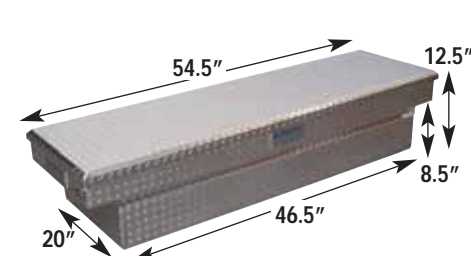

AD170 Fits late model Chevy and GMC 1500 Sportside pickups

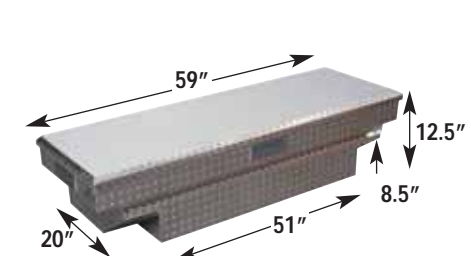

AD180 Fits late model Mazda B2500 and Isuzu B2000 short bed pickups

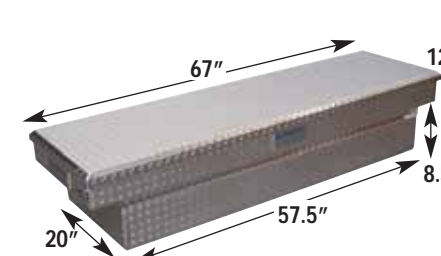

AD190 Fits late model Ford F-150 Sportside, Nissan Titan and Toyota Tundra 05-06 pickups



Double Lid Cross Boxes open wide for more access to parts and tools.

Forward hinge double lids open wider than the center hinge styles. Better access to contents with the protection you want in a double lid box. Gas struts support the lids on the outside corners where you need them. Built-in side pockets provide a convenient way to keep often used small tools or tool accessories close at hand.

Construction

- A** 3 piece fully welded diamond plate body for strength and leak prevention
- B** Gaskets on all four sides of the lid for additional leak prevention
- C** Heavy Duty gas struts assist in lid operation
- D** Linkage guard protects against linkage damage

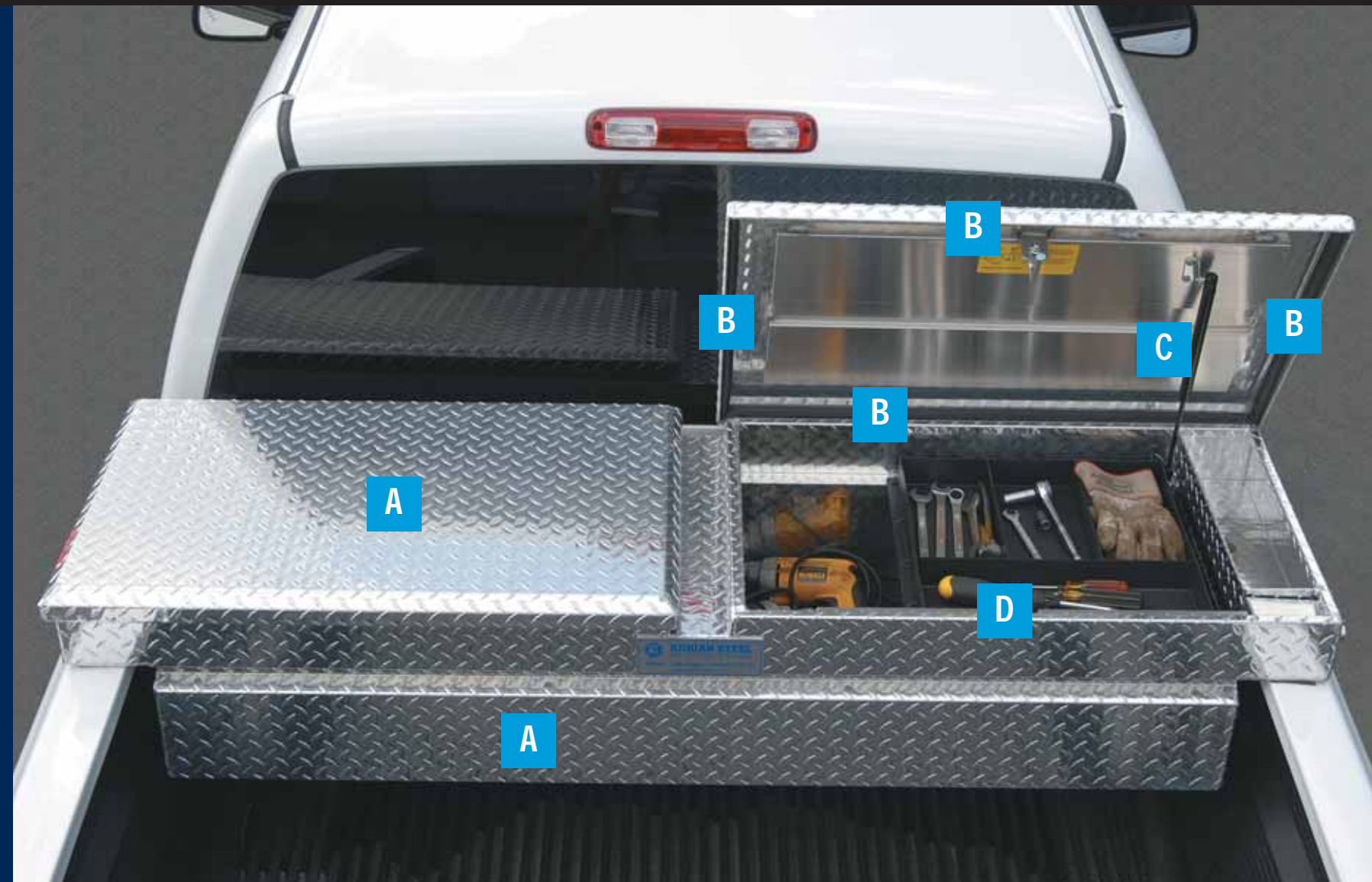

Visibility

Rigid low profile dome lid provides maximum visibility out your rear window.



Easy opening

New and improved automotive push button lock with double bitting lock cylinder.



Security

Fully adjustable intrusion resistant striker keeps contents more secure.



No-drill brackets

Secure the box to your truck without drilling while protecting your truck bed rails.

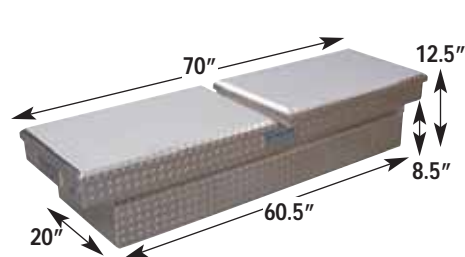

AD200 Fits most late model full size pickups, short and long bed Chevy Silverado, GMC Sierra, Ford F150 Dodge Ram and 2007-on Toyota Tundra

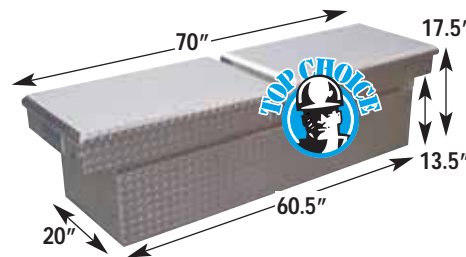

AD201 Fits most late model full size pickups, short and long bed Chevy Silverado, GMC Sierra, Ford F-150, Dodge Ram and 2007-on Toyota Tundra

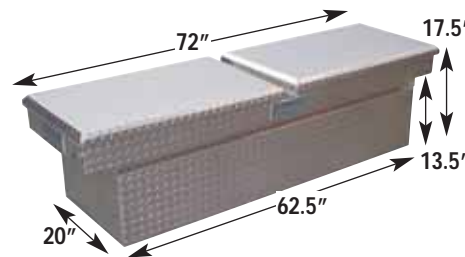

AD201-2 Fits late model Ford Super Duty short bed and long bed pickup trucks

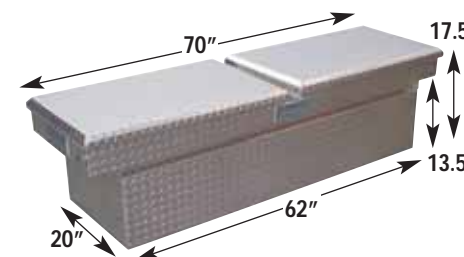

AD201-3 Fits late model Dodge Ram short bed and long bed pickup trucks

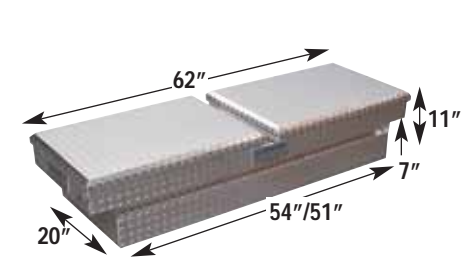

AD220 Fits late model Ford Explorer Sport-Trac, S10 Crew Cab, Chevy Colorado Crew Cab, GMC Canyon Crew Cab, Nissan Frontier, Toyota Tacoma and Dodge Dakota 4-Door

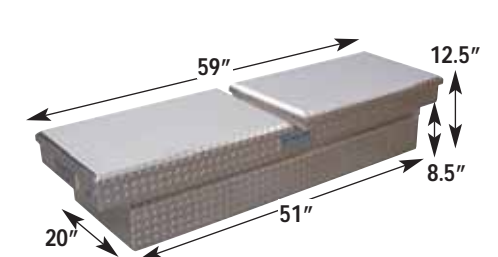

AD250 Fits late model Ford Ranger regular cab and Ranger Super Cab short and long bed pickups

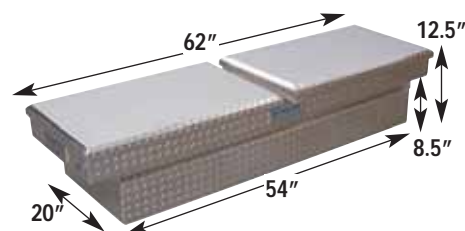

AD260 Fits late model Chevy Colorado, GMC Canyon, Dodge Dakota, Nissan Frontier and Toyota Tacoma short bed and long bed pickups

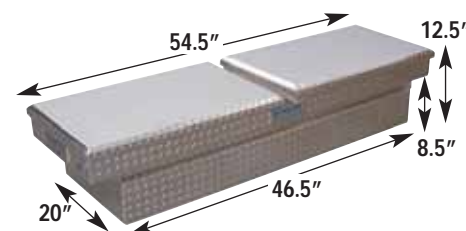

AD270 Fits late model Chevy and GMC 1500 Sportside pickups

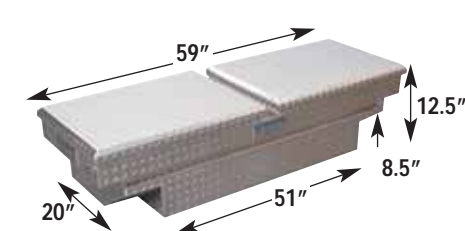

AD280 Fits late model Mazda B2500 and Isuzu B2000 short bed pickups

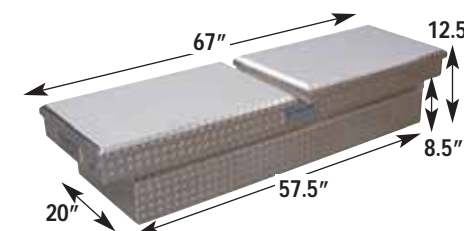

AD290 Fits late model Ford F-150 Sportside, Toyota Tundra 05-06 and Nissan Titan pickups



A knowledgeable sales staff and certified installers are available to assist with your favorite Adrian Steel products to make your vehicle work ready!

Contact your preferred Adrian Steel Distributor today! To locate your local Adrian Steel Distributor visit www.adriansteel.com.

SIDE BOXES

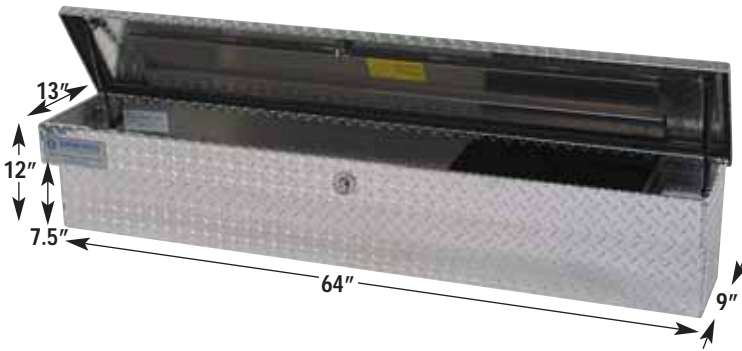

AD302 Fits late model full size Ford, Chevrolet, Dodge, GMC and Mazda long bed pickup trucks. See chart.

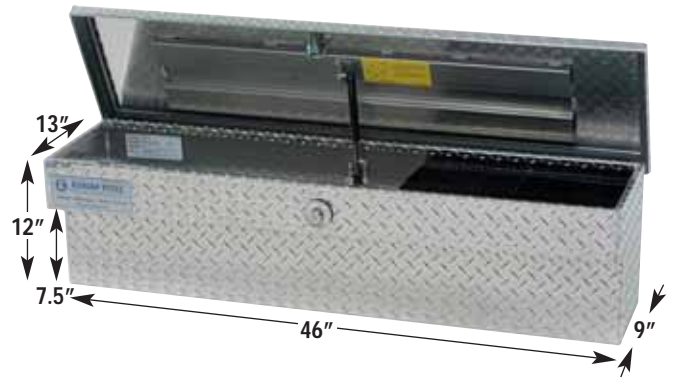

AD303 Fits late model GMC, Ford, Chevrolet, Dodge, Nissan, Toyota, Mazda and Isuzu pickup trucks. See chart.

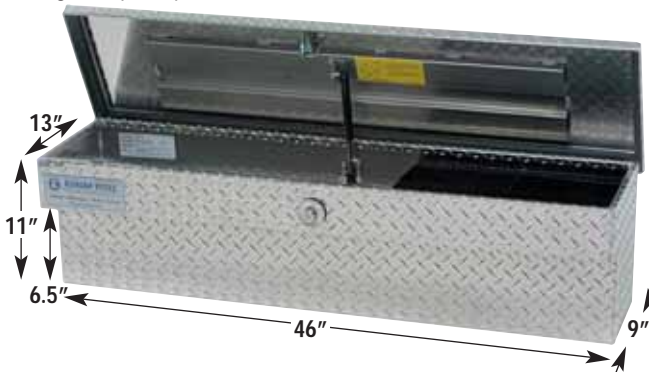

AD350 Fits late model Ford Ranger, Chevy Colorado and GMC Canyon long bed pickups. See chart.

Features and benefits

- Easy glide drawers. Full width recessed conveyor roller at front. Hardened steel roller bearings at rear.
- Outer cabinet made of 14-gauge steel—double side-walls on the drawer add stiffness and resistance to load pressure.
- Drawers are designed to keep water out and contents dry.
- Stow-All accommodates items up to 48" in length. Black low gloss exterior finish for lasting protection and durability.
- Extra dividers available for inside your Stow-All.
- Traction strips are standard on Stow-All models for pickups.
- Easy installation.

Accessories Add more dividers if you need. See chart.



SA-30B Triple Wide Deep



SAJ-30B Triple Wide Shallow



SA-40B Full Wide Deep



SAJ-40B Full Wide Shallow

Stow-All Floor Drawer models

Please state make, model and year of pickup when ordering.

Model	Description	Cabinet Dimensions			Drawer Compartment Sizes			Dividers
		W	H	D	W	H	D	
SA-30B	Triple Wide	30"	12"	51 1/2"	9 5/8"	8 1/2"	48 1/2"	DV 9 (5)
	Deep				19 5/8"	8 1/2"	48 1/2"	DV 19 (5)
SA-40B	Full Wide	40"	12"	51 1/2"	9 5/8"	8 1/2"	48 1/2" (2)	DV 9 (10)
	Deep				19 5/8"	8 1/2"	48 1/2"	DV 19 (5)
SAJ-30B	Triple Wide	30"	8 1/2"	51 1/2"	9 5/8"	5 1/4"	48 1/2"	DVJ 9 (5)
	Shallow				19 5/8"	5 1/4"	48 1/2"	DVJ 19 (5)
SAJ-40B	Full Wide	40"	8 1/2"	51 1/2"	9 5/8"	5 1/4"	48 1/2" (2)	DVJ 9 (10)
	Shallow				19 5/8"	5 1/4"	48 1/2"	DVJ 19 (5)

Note: When using Stow-All's on a pickup with a crossbox, please confirm the depth of the crossbox and available bed length.



Stow-All convenience for your pickup.

Secure weather resistant storage for the bed of your pickup. Easy access to parts and tools. Drawers are easy to open and close because of Stow-All's smooth roller glides. Stow-All can accommodate items up to 48" in length or organize smaller items with adjustable dividers. Models available in 30" or 40" widths and 8-1/2" or 5-1/4" drawer depths.

Floor Drawers
STOW-ALL



A knowledgeable sales staff and certified installers are available to assist with your favorite Adrian Steel products to make your vehicle work ready!

Contact your preferred Adrian Steel Distributor today! To locate your local Adrian Steel Distributor visit www.adriansteel.com.



Keep equipment dry and secure with Adrian Steel's Underbody Boxes.

Adrian Steel's underbody box is built tough to protect tools and equipment from both weather and theft. Designed for quality and built to last, Adrian's underbody boxes are covered under Adrian's 3 year/36,000 miles warranty when installed by an authorized Adrian Steel distributor.

Construction

- A** Strong 14 Gauge galvanneal steel body and door
- B** Linkage guard protects against linkage damage... no bending, no jamming



New compression style T-Handle seals the door. Padlocks can be added to provide double the security!



Coated galvanized cable lanyards provide strength when door is opened



Adrian's exclusive 3 point latching system pulls door tight (Except on UBB2418)



Door is attached by a continuous stainless steel hinge and sealed with automotive grade door gaskets to seal out dirt and water

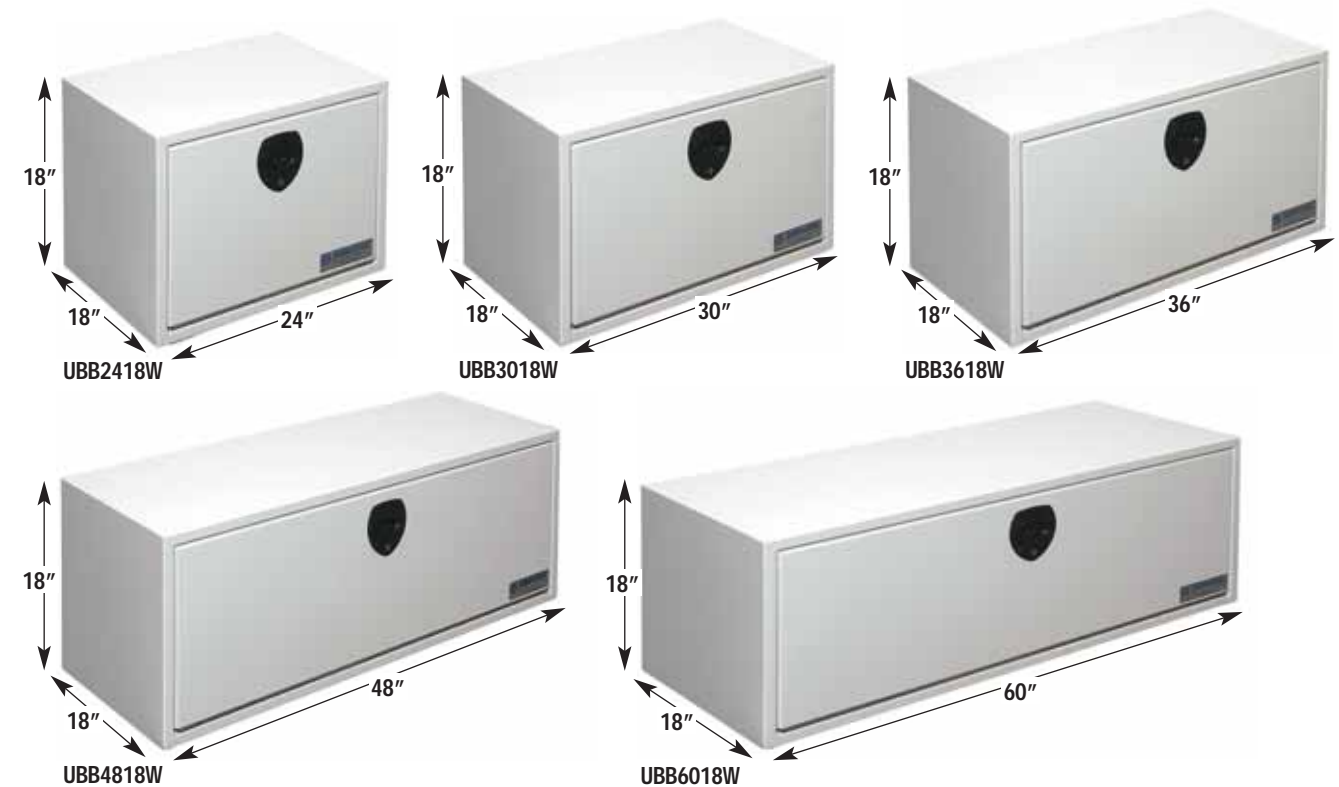
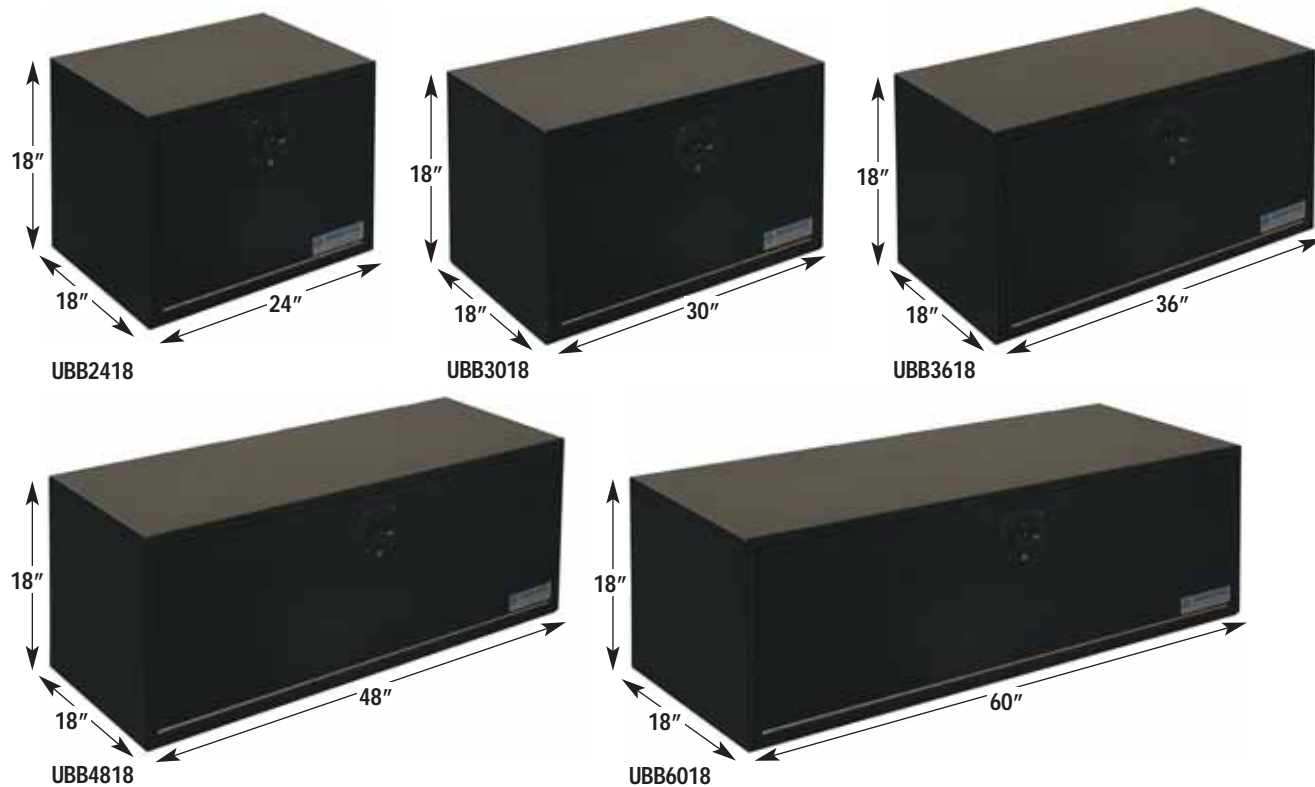



Beefy, good looking rack for today's trucks.

Adrian's new Load Runner rack looks great, and works hard, too. With its beefy, two-inch, high-strength round tubing, Load Runner is rated for the maximum load allowed by truck manufacturers. The removable rear crossbar allows tall items to be carried in the truck bed, and convenient tie-down cleats help secure loads on top or in the truck bed.



Full-Size Pickup Load Runner

Features:

- 2" high strength round tubing
- 51" width inside to inside of truss tubes
- Fits most GM, Ford and Dodge full-size pickups
- Full-Length bed rails for 6' and 8' beds
- Black low gloss or white high gloss powder coat paint

- Easy assembly and installation
- Center crossbar standard
- Removable center and rear crossbar
- 2" square crossbars
- Welded tie down cleats

*Rack payload capacity exceeds truck bed wall capacity rating. Consult your truck manufacturer for recommended bed capacity rating.

Load Runner pickup racks fit Chevy, GMC, Dodge, Toyota and Ford Late Model full-size pickups as indicated in the chart located on page 14.



Easy to remove rear crossbar lets you carry tall items in the truck bed.

Mid-Size Pickup Load Runner

Features:

- 1.75" high strength round tubing
- 51.5" width inside to inside of truss tubes on GM and Dodge mid size pickups

- 48.5" width inside to inside of truss tubes on Ford mid size pickups
- Fits most GM, Ford and Dodge mid-size pickups
- Full-Length 6' bed rails
- Black low gloss or white high gloss powder coat paint

- Easy assembly and installation
- Center crossbar standard
- Removable center and rear crossbar
- 1.75" square crossbars
- Welded tie down cleats

Rack payload capacity exceeds truck bed wall capacity rating.

Consult your truck manufacturer for recommended bed capacity rating.

Load Runner pickup racks fit Chevy, GMC, Dodge and Ford Late model mid-size pickups as indicated in the chart located below.

Load Runner rack fit

Please state make, model, year and length of pickup bed when ordering.

Make	Cat. No.		Model	A-Dim	B-Dim
	Black	White			
Chevy/GMC/Dodge/Ford RD/Nissan/07-on	SLR-8FR	SLR-8FRW	8' Bed Fleetside	91 1/2"	25"
Toyota Full-Size/Regular Cab	*SLR-6FR	*SLR-6FRW	6' Bed Fleetside	71 1/2"	25"
Chevy/GMC/Dodge/Ford RD/Nissan/07-on	SLR-8FE	SLR-8FEW	8' Bed Fleetside	91 1/2"	25"
Toyota Full-Size/Extended Cab	*SLR-6FE	*SLR-6FEW	6' Bed Fleetside	71 1/2"	25"
Ford Super Duty Full-Size/Regular Cab	SLR-8FRS	SLR-8FRSW	8' Bed Fleetside	91 1/2"	29"
Ford Super Duty Full-Size/Extended Cab	SLR-8FES	SLR-8FESW	8' Bed Fleetside	91 1/2"	29"
Ford Super Duty Full-Size/Extended Cab	SLR-6FES	SLR-6FESW	6' Bed Fleetside	71 1/2"	29"
Chevy Colorado, GMC Canyon, Dodge Dakota, Regular Cab	MSLR-6FRB	MSLR-6FRW	6' Bed Fleetside	68 3/8"	22 7/8"
Ford Ranger Regular Cab	MSLR-6FRB	MSLR-6FRW	6' Bed Fleetside	68 3/8"	22 7/8"
Chevy Colorado, GMC Canyon, Dodge Dakota, Extended Cab	MSLR-6FEB	MSLR-6FEW	6' Bed Fleetside	68 3/8"	22 7/8"
Ford Ranger Extended Cab	MSLR-6FEB	MSLR-6FEW	6' Bed Fleetside	68 3/8"	22 7/8"

Note: Load Runner rack models SLR-6FR and SLR-6FE do not fit GM shortbed crew cab pickups.
 Note: Wind deflector included with extended cab Load Runner pickup racks.
 Note: Load Runner racks do not fit the Toyota Crew Max truck.

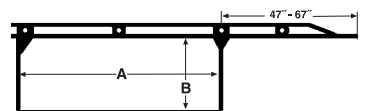

How to order tool box envelope

Rack dimensions for A (inside length) and B (inside height) are contained in the Load Runner rack fit Chart. Dimensions show available area for mounting cross and side boxes. Side rail height is 8" above cross supports. Cab over extension is 47" for regular cab models and 67" for extended cab models.

Note: Exterior ladder rack and accessory equipment can cause increased cab area noise on vans and pickups.



Adrian Steel's hard-working ladder rack

Easy on, easy off uprights that can be removed for your leisure time activities. This unique design allows the rack to be installed without cutting or drilling of the LOADFLEX.

Constructed of 1-1/2" x 1-1/2", 14 gauge wall steel tubing with 250lb. payload capacity. Powder coat black paint finish provides years of maintenance-free service. Rest arms easily adjust from 20-1/2" to 35" for wide ladders and feature slot-through bolt design to prevent separation. Plastisol rung stop and rope hooks are welded-on for securing loads to the rack. This unique design allows the rack to be installed without cutting or drilling of the LOADFLEX. Fits all late model GM, Ford, Dodge full-size and mid-size trucks.



Full-Size Pickup Rack model

Please state make, model, year and length of pickup bed when ordering.

	1.5 X 1.5 LOADFLEX ladder rack	
	Black	White
Chevy/GMC		
8' Bed Fleetside ('88-On)	LF250	LF250W
6' Bed Fleetside ('88-On)	LF250	LF250W
Dodge		
8' Bed Fleetside ('94-On)	LF250	LF250W
6.5' Bed Fleetside ('94-On)	LF250	LF250W
Ford		
8' Bed F-250/350 SD ('99-On)	LF250	LF250W
8' Bed F-150/250 LD ('97-On)	LF250F	LF250FW
6.5' Bed F-250/350 SD ('99-On)	LF250	LF250W
6.5' Bed F-150/250 LD ('97-On)	LF250F	LF250FW

Mid-Size Pickup Rack model

Please state make, model, year and length of pickup bed when ordering.

	1.5 X 1.5 LOADFLEX ladder rack	
	Black	White
Chevy/GMC		
7' Bed S-Series ('94-On)	LFJ250	LFJ250W
6' Bed S-Series ('94-On)*	LFJ250	LFJ250W
Dodge		
6.5' Bed Dakota ('96-On)	LFJ250	LFJ250W
Ford		
7' Bed Ranger ('96-On)	LFJ250	LFJ250W
6' Bed Ranger ('96-On)	LFJ250	LFJ250W

* Note: Includes Extended Cab Models.



A knowledgeable sales staff and certified installers are available to assist with your favorite Adrian Steel products to make your vehicle work ready!

Contact your preferred Adrian Steel Distributor today!
To locate your local Adrian Steel Distributor visit www.adriansteel.com.

LOAD RUNNER

Customize your Load Runner with Adrian Steel accessories



RS3 Ratchet Strap
7' canvas web strap rated at 600 lbs. with hook ratchets to tightly hold ladders and cargo to the rack.



LS4 Ladder Stop Kit
Aluminum rung stop with stainless steel "U"-bolts attaches to crossbars of the rack.



BS2 Light Mount Plate
6" x 9" steel plate with stainless steel "U"-bolts attaches to cross bars or side rails for beacon or strobe lights.



75-1 Light Mount Kit
Galvanized stand with 4" pipe screws on to base of light for raising light above mounting surface. Includes BS-2 Light Mount Plate, for mounting to crossbars and side rails.



80-1 10' 6" and 80-2 12' 6" Aluminum Conduit Carrier.
063" diamond tread aluminum construction. Two piece design allows for efficient shipping and storage. Lift-up rear door features a spring assist for easy access and lockable swivel closure for security. Bolt-on plate enables access to front of carrier.

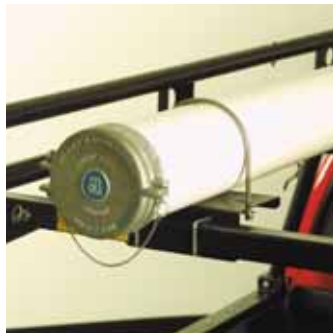

70-3 4" Diameter PVC Conduit Carrier Kit with Mounting Plate.
Use with 4-1/2" O.D. PVC pipe schedule 40. PVC tubing not supplied.



WG21 Window Guard/ Black or WG21W Window Guard/White
Use with standard Load Runner for all Chevy/GMC/Ford Regular Duty pickups.

WG21S Window Guard/ Black or WG21SW Window Guard/White
Use with Load Runner on Ford Super Duty only. Rugged 1.25" X 1.25", 13 gauge tube frame with expanded metal screening. Offers maximum visibility through the cab window and superior strength due to the welded, no drill design.



Utility Hook for Load Runner Ladder Racks. The steel utility hook is 8.5" high by 6" deep and is universally designed to fit fullsize, midsize, and service body Load Runners.

LRA-UH1 – black
LRA-UH1W - white



Load Divider for Load Runner Ladder Racks. The steel load divider is 8.5" high by 6" deep and is universally designed to fit fullsize, midsize, and service body Load Runners.

LRA-LD – fullsize, black
LRA-LDW – fullsize, white
LRA-LDMS – midsize, black



Adrian's new Service Body Load Runner rack looks great, and works hard too.

Features two-inch high-strength round tubing, a removable rear crossbar that allows tall items to be carried in the truck bed and convenient tie-down cleats to help secure loads on top or in the truck bed. The Service Body Load Runner rack fits a variety of service bodies. The standard rack fits 8' service bodies with either a regular cab truck or an extended cab truck.

Service Body Load Runner is universally designed to accommodate single and dual wheel chassis. Bodies that are 9' long will require

the SBE9 that adds one foot of length to the standard rack. 11' long bodies will require the SBE11.

SBLR-8FR Service Body Load Runner
8' Regular Cab

SBLR-8FE Service Body Load Runner
8' Extended Cab

Load Runner Service Body Features:

- 2" high-strength round tubing
- 50.7" width inside to inside of truss tubes
- Fits most GM, Ford and Dodge chassis
- Black low gloss powder coat paint
- Easy assembly and installation
- Center crossbar standard
- Removable center and rear crossbar
- 2" square crossbars
- Welded tie down cleats



Note: The Load Runner Service Body Rack fits a variety of the leading service body manufacturers. Due to the large number of body configurations, the Service Body Load Runner rack will not fit all bodies. To ensure proper fit and finish, please contact your local Adrian Steel Distributor. Please note the following exceptions:

- Taillights must be vertical, external mount or bumper mount. Lower horizontal lights are acceptable.
- Master Lock system may be incompatible with Service Body Load Runner. Contact your local distributor to confirm fit.
- SBEL extension leg kit is required for low profile bodies.
- Service Body Load Runner is not compatible with canopy tops.
- Ultra wide opening may result in mounting brackets protruding into the bed storage area.

continued on page 18



SBEL- Extension kit
for low profile service
bodies (2 per set)

SBE9- Extension kit
for 9' service bodies

SBE11- Extension kit
for 11' service bodies

Exceptions Continued:

- The Load Runner Service Body Rack will not fit fiberglass service bodies.
- Load Runner Service Body Rack will not fit Super Duty Ford Trucks with a low profile service body.
- Ford Super Duty Trucks with a standard service body will require SBEL Extension Kits.

Please note: The Load Runner Service Body rack has been designed and manufactured to carry an evenly distributed 1,000 pound load. This rating only applies if:

1. The Ladder Rack has been installed in a manner consistent with the supplied installation instructions.
2. The manufacturer of the service body verifies that the service body itself is capable of carrying a 1,000 pound load, in addition to the weight of the mounted ladder rack.

Remember: The load bearing capacity of the Load Runner is no greater than the capacity of the service body to which it is attached. If the service body manufacturer cannot verify the load carrying capacity of their service body, Adrian Steel Company recommends a maximum 500 pound load capacity (evenly distributed.)



Create a mobile workshop for your pickup

Trade packages offer quick, convenient access to inventory and tools from outside the vehicle. Specialized interiors have abundant, secure storage. Top off your truck with an industry specific trade package from Adrian Steel.

Features: Use with commercial cab high plus 6" tops. Storage access through side and rear doors of top. Access drawers and shelving from outside truck. Shelving hugs bed sides for more center aisle space.

Vehicle fit: Full and compact pickup bed lengths as indicated. Package installation requires removal of bed liners. Shelving heights require use of cab high plus 6" model tops. Lift-up or sliding side doors required on pickup top for interior package access.

How to order: Please state make, model, year and length of pickup bed when ordering.

Note: Avoid vehicle overloading. Determine the proper vehicle payload capacity required for what your intended to carry. Deduct add-on weights of top, interior package, ladder rack, tools and inventory from the available payload capacity to ensure you have not overloaded your vehicle.

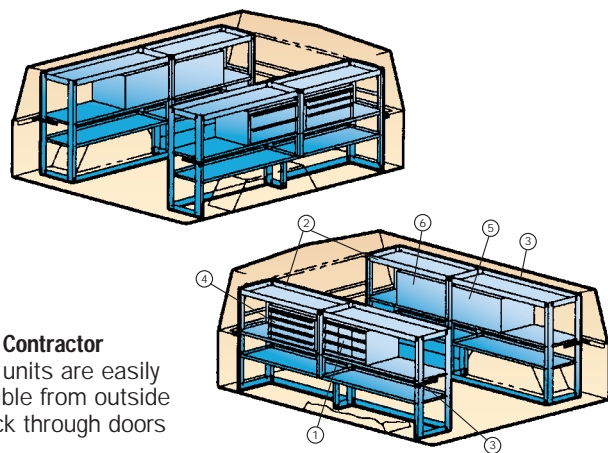

General Contractor
Drawer units are easily accessible from outside the truck through doors of top.

2841 General Contractor Package/6'-8' Pickup Bed

Item	Model	Description	Qty.
1	DS36012H	9-Drawer Cluster	1
2	MD522	KD Unit 12" x 36" x 30"	2
3	MD523	KD Unit 12" x 36" x 36"	2
4	9	4-Drawer Shallow	1
5	19	2-Drawer Medium	1
6	919	3-Drawer Combo	1

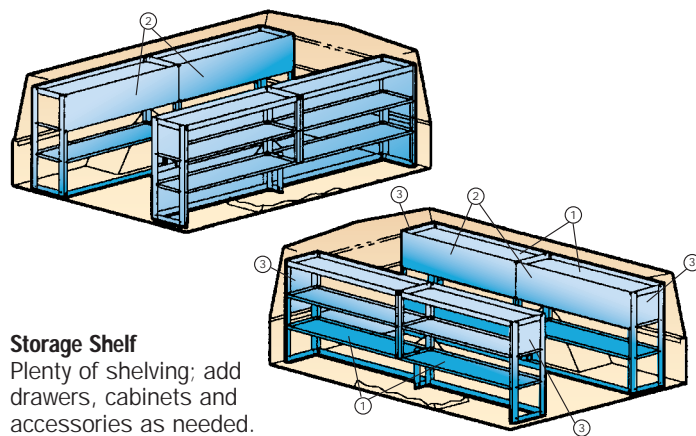

Storage Shelf
Plenty of shelving; add drawers, cabinets and accessories as needed.

2890 Storage Shelf Package/7'-8' Pickup Bed

Item	Model	Description	Qty.
1	MD523	KD Unit 12" x 36" x 36"	4
2	BP1236	Back Panel, 12" x 36"	4
3	EP1014	End Panel, 14"	4

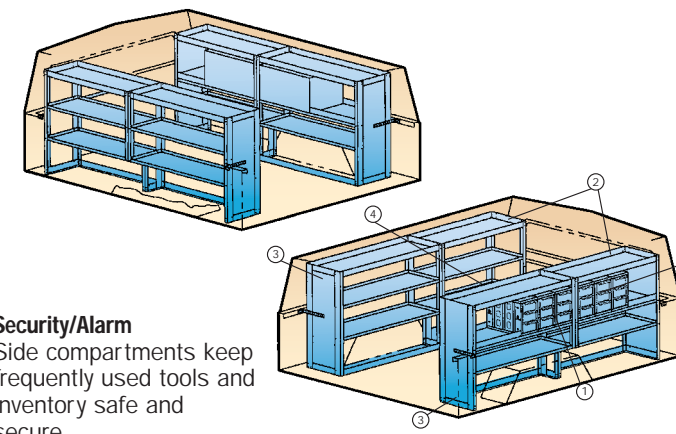

Security/Alarm
Side compartments keep frequently used tools and inventory safe and secure.

2888 Security/Alarm Package/6'-8' Pickup Bed

Item	Model	Description	Qty.
1	DS36012H	9-Drawer Cluster	2
2	MD522	KD Unit 12" x 36" x 30"	2
3	MD523	KD Unit 12" x 36" x 36"	2
4	BP1236	Back Panel, 12" x 36"	4
5	FR18	Floor Rail	2
6	FR24	Floor Rail	2

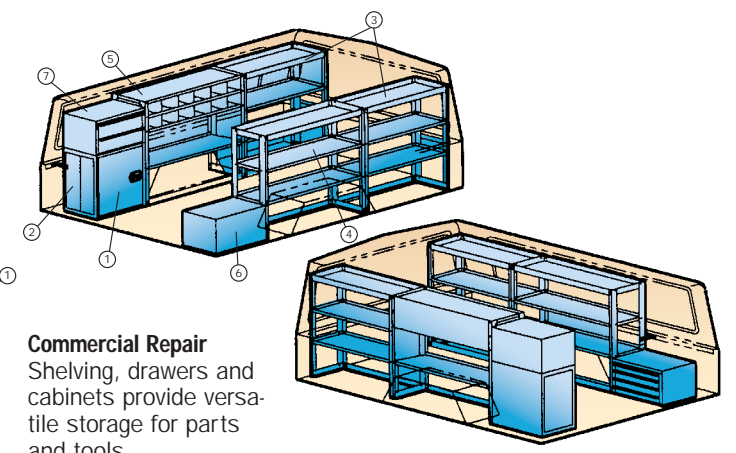

Commercial Repair
Shelving, drawers and cabinets provide versatile storage for parts and tools.

2889 Commercial Repair Package/8' Pickup Bed

Item	Model	Description	Qty.
1	12	Cabinet	1
2	12A	End for #12 Cabinet	1
3	MD522	KD Unit 12" x 36" x 30"	2
4	MD523	KD Unit 12" x 36" x 36"	1
5	17970-0	KD Frame for MD 517	1
6	9	4-Drawer Shallow	1
7	19	2-Drawer Medium	1

Ladders are safe and secure with Grip-Lock Racks.

Grip-Lock ladder racks reduce abrasion to the ladder rails by applying a constant tension to rungs of the ladder while in the locked position. The built-in locking mechanism can be padlocked (not included) for security if desired. Ladder racks are available in 5' and 6' lengths between cross supports and fit commercial tops for 6', 7' and 8' pickup bed lengths.

Features

Outer rail and horn assist in loading ladders. Lock down mechanism secures ladders to rack. Reduces vibration wear to ladder rails. Rails quickly load ladders on racks.



68-3 Step Ladder Support Kits carry step ladders shorter than the distance between the front and rear cross supports. Relocate front clamp bracket from ladder rack to auxiliary support, and then adjust to fit most step ladders. Kit includes one polymer adhesive-back ladder pad.



69-4 Extension Kit adds 24 inches to overall ladder rack extension kit length and provides additional support and protection when carrying longer ladders. Kit includes plastisol side rails and cross support with two polymer ladder pads.



70-1 4" Diameter PVC Conduit Carrier Kit contains: Aluminum cast hinged lid and end cap, two stainless steel "U"-bolts, adhesive sealant and fasteners. Use with 4-1/2" O.D. PVC pipe schedule 40. PVC tubing not supplied.

70-2 6" Diameter PVC Conduit Carrier Kit (above). Use with 6-5/8" O.D. PVC pipe schedule 40. PVC tubing not supplied.



73 Ladder Pad Kit includes four polymer pads with adhesive backs. Provides protection against contact damage to ladder rails.



75 Light Stand raises light 4" above ladder for improved visibility.



76 Rail Cover Kit includes covers for ladder rack horn and rail to protect ladder rails from contact damage.

Grip-Lock Ladder Rack models

Full-size and compact pickups.

Model	Description	Compact truck Bed length	Between supports	Cross support width
61-7	Series 61 Single Lock Down	Longbed	72"	57"
61-6	Series 61 Single Lock Down	Shortbed	60"	57"
63-7	Series 63 Double Lock Down	Longbed	72"	57"
63-6	Series 63 Double Lock Down	Shortbed	60"	57"

Note: Grip-Lock ladder racks bolt through roof and require roof reinforcements in the top for a secure mount. Request roof reinforcements be installed in your top when ordering from your supplier.

Note: Exterior ladder rack and accessory equipment can cause increased cab area noise on vans and pickups.

COMMERCIAL TRUCK EQUIPMENT

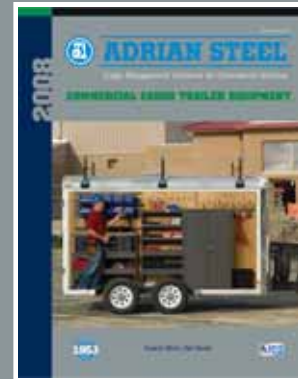
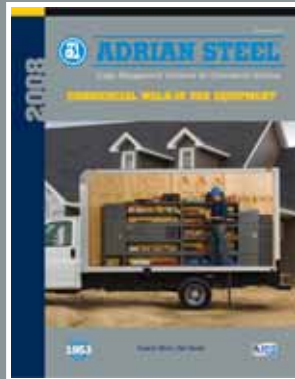
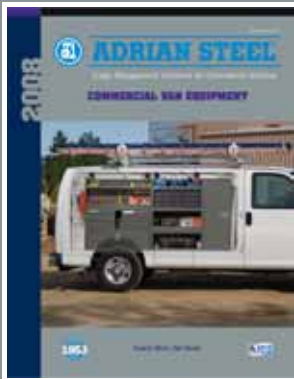

2008

Look for commercial truck and van catalogs from your Adrian Steel distributor or log onto www.adriansteel.com

3 YEAR
36,000 mile
BEST WARRANTY

Adrian Steel warrants its products to be free from defects in material and workmanship, under normal use and service for a period of three years or 36,000 miles, whichever first occurs, after the date of delivery to the original retail

purchaser, when installed by an authorized Adrian Steel Company distributor. Products purchased and not installed by authorized distributors will be warranted for a period of twelve months from the time of customer purchase.

CPU38M0907

Distributed by



ADRIAN STEEL®

906 James Street, Adrian, Michigan 49221-3996
517-265-6194 Fax: 517-265-5834
Toll Free 800-677-2726 www.adriansteel.com
info@adriansteel.com