

TS/ISO Registered



# ADRIAN STEEL®

*Cargo Management Solutions for Commercial Vehicles*

## COMMERCIAL CARGO TRAILER EQUIPMENT

2008



Expect More. Get More!





**Trade Packages and Modular Units designed to meet a variety of needs for Cargo Trailers.**

Select one of our trade-specific interior packages. Or design your own trailer by mixing and matching from our modular components.

- A** Adjustable shelving is 60" high, 12" deep and comes in widths of 32", 42" and 52". Great for storing tools and parts. Easily add drawer units and locking door kits. For more information see page 3.
- B** Drawer Components are essential for the storage of small parts and fasteners. DC Units are available in 6" and 12" widths, 12" deep and 12" high. For additional information please see page 8.

- C** Locking Cabinets provide secure storage for jobsite tools. The compressed T-Handle does not protrude into the aisle. For more information please see page 7.
- D** Lock and Latch Drawer Units are great for storing those small parts and tools. For more information please see page 8.
- E** Lockable deep drawer units store parts and can be used to create a workbench. See page 8 for more information.
- F** Masonite Work Bench Top measures 42" wide by 18" deep and provides a work bench inside the trailer from which you can work from. See Page 3 for more information.
- G** Store ladders safe and dry inside the trailer and off the floor with the LK8 Ladder Keeper. See Page 10 for more information.

Note: Interiors designed for 12' long trailers.  
 Note: Floor mat not currently available.  
 Note: Trailers with wheel wells may require equipment modification. Please contact your local Adrian Steel distributor.



- Why Adrian Steel trailer products?**
- Holds up to stress when trailer is in motion
  - Stronger than wood
  - Secure storage
  - Modular design
  - Commercial grade

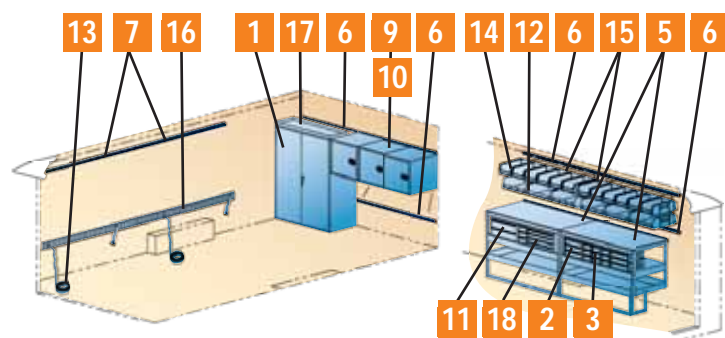

**3969 General Package**

Item	Model	Description	Qty.
1	CL1860	Cabinet Locker	1
2	DC12	Drawer Component 12" Wide	2
3	DC6	Drawer Component 6" Wide	4
4	LK8	Ladder Keeper 8" (not shown)	1
5	MD4842T	Desk Module 48x42x24	2
6	TRK52	Trailer Z-Rail Kit 52" LG	6
7	TRK60	Trailer Z-Rail Kit 60" LG	2
8	UH51	Z-rail Acc. Hook (not shown)	10
9	1	Cabinet 18x22x18	3
10	1A	Shelf for #1 Cabinet	1
11	19	2-Drawer Medium	1
12	22	Linbin 30-250 Blue 15x16x7	6
13	23896-0	E-Track Strip 12" W/Cam Blk	2
14	24	Linbin 30-240 Blue 15x8x7	12
15	29193-0	Rest Asm. 2 Row 51"	2
16	29687-0	E-Track 128" or 10' 8"	1
17	4A	Parts Tray 2x12x36	1
18	9	4-Drawer Shallow	1

Note: Interior designed for 16' long trailers.

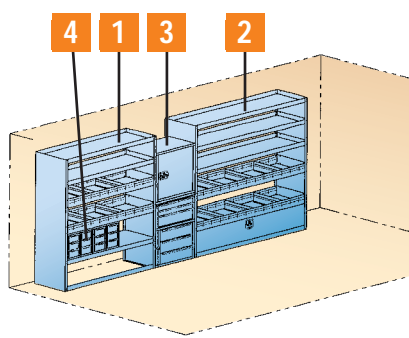

**3682 Builder/Remodeler Package**

Item	Model	Description	Qty.
1	HD-42WPT	Adjustable HD Shelving Unit	1
2	MD707T	KD Storage Unit	1
3	MD603T	Drawer Cabinet Module	1
4	DS46012	12 Drawer System	1
5	JD42WPT	Jumbo Adjustable Shelving Unit	1
6	MD708T	Work Bench Module	1
7	TA1	Hook Bar	2

Note: Interior designed for 12' long trailers.

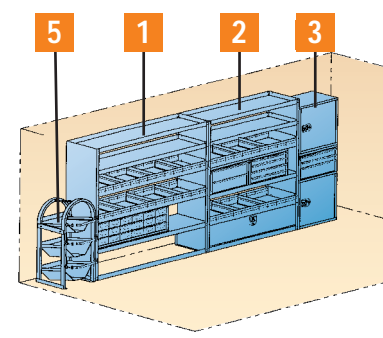
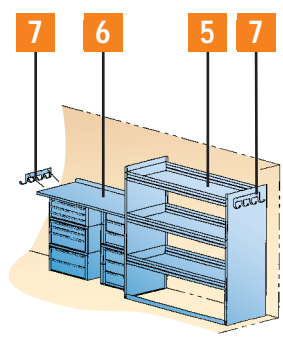

**3683 Plumbing, Heating, A/C Repair Package**

Item	Model	Description	Qty.
1	MD706T	KD Storage Unit	1
2	MD704T	KD Storage Unit	1
3	MD601T	Drawer Cabinet Module	1
4	MD707T	KD Storage Unit	1
5	WTR130250	Three Tank Rack	1
6	WTR230150	Three Tank Rack	2

Note: Interior designed for 12' long trailers.

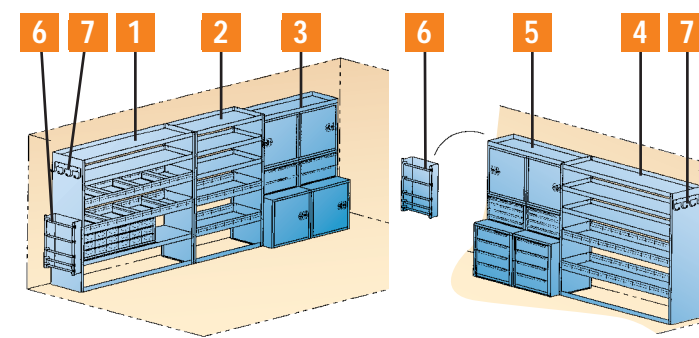

**3684 Utility/Gas & Electric Package**

Item	Model	Description	Qty.
1	MD706T	KD Storage Unit	1
2	HD-32WPT	HD Adjustable Shelving Unit	1
3	MD701T	Drawer Cabinet Module	1
4	HD-52WPT	HD Adjustable Shelving Unit	1
5	MD702T	Drawer Cabinet Module	1
6	WRH5	5 Bar Wire Reel Holder	2
7	TA1	Hook Bar	2

Note: Interior designed for 12' long trailers.



Shelving fits where you need it.

Adjustable shelving units are available in 14", 18" and 24" depths. Shelves feature a two or four inch containment lips and the ability to invert the shelves to add steel or composite drawer units. Shelving units include the Z-Rail kit for installing the product to the trailer. Durable, adjustable and strong shelving units give you exactly what you need right where you need it.



A knowledgeable sales staff and certified installers are available to assist with your favorite Adrian Steel products to make your vehicle work ready!

Contact your preferred Adrian Steel Distributor today! To locate your local Adrian Steel Distributor visit [www.adriansteel.com](http://www.adriansteel.com).



A solid worktop with deep shelves for storage-all built into one

#### MD4842T – Adjustable Shelving Unit and Work Bench

Deep shelves for storage below and a solid work top built into one. The MD4842T features two bolt deep shelves measuring 24"D x 42"W with 4" deep containment lips. The B-leg design allows for trailers with in-board wheel wells. Shelves can be inverted to add steel or composite drawer units. The MD4842T measures 48"H x 42"W x 24"D. Note: Plywood work top not included.

Model	Description
MD4842T	Adjustable Shelving Unit and Work Bench



Heavy Duty Jumbo Deep Series

JD (Jumbo Deep) Series shelving units are available in 18" and 24" depths. Channel reinforced shelf bottoms and 4" deep shelf lips for added strength. 18" deep units contains three 18" deep shelves with square end panels. 24" deep units contain three 24" deep shelves with square end panels.

Model	Overall Size	Open Shelf Space
JD42WPT	42" 60" 18"	15.75 sq ft
JD52WPT	52" 60" 18"	19.50 sq ft
JD48WPT	48" 60" 24"	24 sq ft
JD60WPT	60" 60" 24"	30 sq ft



Heavy Duty Series

The HD (heavy-duty) Series contains five fully adjustable shelves. Three 14" deep shelves with a 2" lip and two 14" deep heavy-duty shelves with a 4" lip. Shelf gussets, end panel braces and full floor-rail provide extra strength.

Model	Overall Size	Open Shelf Space
HD-32WPT	32" 60" 14"	15.56 sq ft
HD-42WPT	42" 60" 14"	20.42 sq ft
HD-52WPT	52" 60" 14"	25.28 sq ft

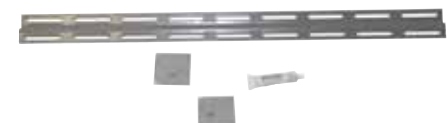

Trailer Fastener Kits include z-rail for mounting to the wall of the trailer, floor plates for mounting to the floor of the trailer and fasteners for both. All trailer shelving units and modules include the necessary fastener kits. Additional fastener kits can be ordered. See below for fastener kit product number.

Model	Description
TRK18	Trailer Fastener Kit, 18"
TRK32	Trailer Fastener Kit, 32"
TRK42	Trailer Fastener Kit, 42"
TRK48	Trailer Fastener Kit, 48"
TRK52	Trailer Fastener Kit, 52"
TRK60	Trailer Fastener Kit, 60"



Adrian's modules and shelving maximize storage for cargo trailers.

Adrian's storage modules offer the best of both worlds. Combinations of cabinets, drawer units and shelving units provide maximum storage for different tools and equipment. Choose from our

pre-configured storage modules that include the Z-Rail kit for installing the product to the trailer or create a custom storage module that works best for you.

#### Bin and Rest Assembly

Portable blue bins are great to take to the job site. The rest assembly is 51" long and can accommodate three No. 22 or six No. 24 bins per row. The spring loaded lock bar holds bins in place. Add dividers to the blue bins with the No. 23 plastic divider.

Model	Description
29193-0	One row - 51" Rest Assembly for Trailers



Two 51" rest assemblies shown with (2) TRK60 z-rail kits and blue bins.



- Large Capacity
- Secure Storage



#### CL1860 Storage Locker

Large storage capacity for all your tools and equipment! The CL1860 measures 60"H x 18"D x 36"W. Featuring two hinged doors with a two point locking system to secure stored items, three bolt in shelves and a bolt in steel back panel. Assembly required.



#### MD601T Drawer/Cabinet Module

combines the convenience of lockable drawers and cabinets. Features two large lockable cabinets both with an adjustable shelf, and one 3-drawer combo with a plastic parts tray in each of the two shallow drawers. Measures 18" W, 56" H, 12" D.



#### MD602T Drawer/Tray Module

features three lockable 3-drawer mediums and a parts tray on top with a 2" lip. Measures 18" W, 56" H, 12" D.



#### MD603T Drawer/Cabinet Module

contains one large lockable cabinet with an adjustable shelf, one 3-drawer combo, one 3-drawer medium and a parts tray with a 2" lip for added storage. Measures 18" W, 54" H, 12" D.



#### MD604T Drawer/Cabinet Module

has four large lockable cabinets with adjustable shelves, and eight shallow drawers. Cabinets feature an open side and combine to form a 36" wide compartment. Each drawer contains a removable plastic parts tray. Measures 18" W, 56" H, 12" D.



#### MD605T Drawer/Cabinet Module

combines two open sided lockable cabinets with adjustable shelves, ten medium drawers and a large 36" parts tray with a 2" lip across the top. Measures 36" W, 54" H, 12" D.



#### MD701T Drawer Cabinet Module

has four locking cabinets, top tray, and four medium drawers. Measures 36" W, 58" H, 12"/18" D.



#### MD702T Drawer Cabinet Module

has top tray, two locking cabinets, eight small and eight large drawers. Measures 36" W, 60" H, 12"/18" D.



#### MD704T Storage Unit

features lockable door kit cover, divided shelf storage, four small and two medium drawers. Measures 42" W, 60" H, 14" D.



has a masonite work top with a mix of small and medium drawer units. Includes Nos. (2) #8, #9, #19, #919, #54. Measures 42" W, 38" H, 14"/18" D.



**Customize your trailer to fit the job with Adrian Steel accessories.**

Organization is the key when you need to find something fast. Adrian's modular components and accessories offer a wide variety of drawer units, cabinets, hooks and lockers to store your parts and equipment. Whether you need to add to a shelving unit or create a storage module, Adrian's modular components and accessories have what you need.



**UH5T Utility Hooks** Clean up your trailer floor by hanging shovels, extension cords, rakes and brooms on this versatile utility hook. The powder coated steel hook easily slips onto Adrian's Z-Rail without the need for fasteners to hand those items normally found on the ground. UH5T utility hooks are sold individually.

Model	Description
UH5T	Utility Hooks for Z Rail

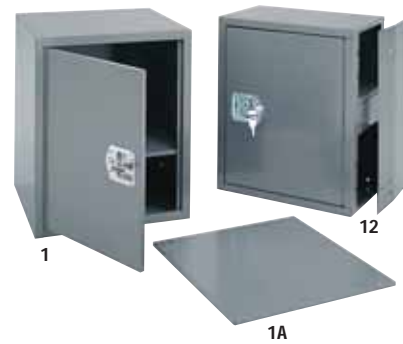

**Shelf Cabinets** are available in 12" and 18" front to rear lengths and can be used free standing or are perfect for stacking with our lockable drawer units. 18"W x 22"H x 12"L cabinets feature an open side and can be combined for side-by-side use holding items up to 35" long. Optional end panel can be added to close off side when required. Shelf cabinets include adjustable shelf that can be removed if required and optional foam liner kits can be added for extra protection and to reduce vibrations. Cover cabinets provide a solid surface to stack modular drawers, cabinets and bins. Cabinets come with locking recessed tee-handles for secure storage and receive a durable gray powder coat finish.

Model	Description	Cabinet Size
1	Shelf Cabinet	18"W x 22"H x 18"L
12	Shelf Cabinet Open Side	18"W x 22"H x 12"L
1A	Optional Shelf	No. 1
12A	Optional End Panel	No.12
FL1	Optional Foam Kit	No. 1
FL12	Optional Foam Kit	No. 12



**Cabinet Lockers** feature a 46" high storage space with 3 removable shelves in the full door model and 33" high storage area and with 2 removable shelves in short door model. Locker doors are reversible for door opening flexibility and feature locked recessed tee-handles for security. Locker cabinets taper from 14" to 12" from front to back in depth at top and bottom to maximize aisle space.

Model	Description	Cabinet Size
CL1446R	Cabinet Locker Full Door	18"W x 46"H x 14"D
CL1446D	Cabinet Locker Short Door	18"W x 46"H x 14"D



**Drawer Units –Lock 'n Latch System**

Units are available with 2, 3 or 4 drawers with depths of 2-1/2" or 5". Exclusive Lock 'n Latch system provides a choice of drawers open, drawers retained or drawers locked position selections. Drawers feature a one-piece no-weld construction for durability with heavy-duty drawer glides for support and smooth drawer operation. Drawers and glides can be repositioned within cabinet for increased storage flexibility. 2-1/2" deep drawers come with tough ABS divided and removable trays perfect for nuts, bolts, screws, connectors and etc. 5" deep drawers can be divided into compartments using optional metal "egg crate" dividers. Optional Fitted Foam Kits cover side and bottom of 5" drawers for extra protection and reduced vibration.

Model	Description	Drawer Size (Qty)	Cabinet Size
19	2 Drawer Medium	16" W x 5" D x 11-1/2" L (2)	18"W x 12"H x 12"L
919	3 Drawer Combo	16" W x 2-1/2" D x 11-1/2" L (2) 16" W x 5" D x 11-1/2" L (1)	18"W x 12"H x 12"L
9	4 Drawer Shallow	16" W x 2-1/2" D x 11-1/2" L (4)	18"W x 12"H x 12"L
27	Divider Kit	Nos. 19 or 919 Drawer (1)	13-3/4"W x 2-3/4"H x 11-3/4" L
FL19	Foam Liner Kit	No. 19 Drawer (1) or 919 Drawer (1)	

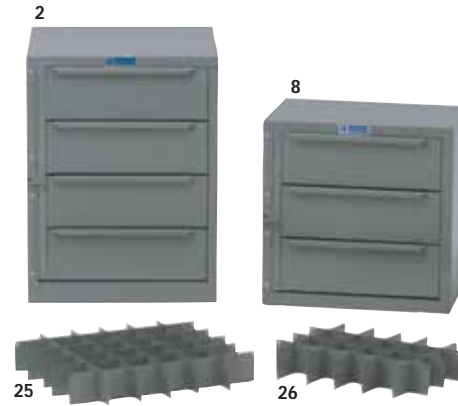

**Drawer Units – Locking Hinge and Hasp**

Units are available with 3 or 4 drawers with a depth of 5". Hinge and hasp can be locked with a padlock (not included) for security. Drawers feature a welded construction and reinforced drawer slides for strength. Drawers can be divided into compartments using optional metal "egg crate" dividers. Optional Fitted Foam Kits cover side and bottom of 5" drawers for extra protection and reduced vibration.

Model	Description	Drawer Size (Qty)	Cabinet Size
8	3 Drawer Medium	16" W x 5" D x 11-1/2" L (3)	18"W x 18"H x 12"L
2	4 Drawer Medium	16" W x 5" D x 17-1/2" L (4)	18"W x 24"H x 18"L
25	Divider Kit	No. 2 Drawer (1)	15-1/2"W x 2-3/4"H x 17-1/2" L
26	Divider Kit	No. 8 Drawer (1)	15-1/2"W x 2-3/4"H x 11-1/2" L
FL2	Foam Liner Kit	No. 2 Drawer (1)	
FL8	Foam Liner Kit	No. 8 Drawer (1)	

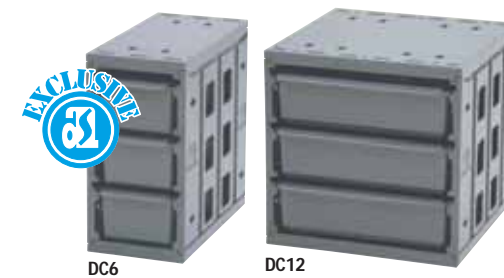

**Drawer Components**

Store and index small parts with our flexible and rugged composite drawer components. Drawer Components are made of a hi-impact polymer for a quiet operation. Drawer retention stops prevent drawers from coming open while the vehicle is in transit. Each drawer comes with 2 dividers and 7 divider slots for easy organization. Choose from Adrian Steel's pre-configured drawer systems or create your own drawer system from the base models. The base models include the DC6 which features 3 drawers in a 6" wide unit and the DC12 which features 3 drawers in a 12" wide unit. The interlocking feature allows you to add multiple combinations vertically or horizontally.

Model	Description	Cabinet Size
DC6	Base 3 drawer narrow model	6"W x 12"H x 12"D
DC12	Base 3 drawer wide model	12"W x 12"H x 12"D
DS06212V	Drawer System (2) DC12's	12"W x 24"H x 12"D
DS36012H	Drawer System (3) DC6's	18"W x 12"H x 12"D
DS46012	Drawer System (4)DC6's	12"W x 24"H x 12"D



**Tote Trays and Cases**

Removable tote trays and cases allow you to conveniently take small parts and tools right to the job site. 18-1/2"W x 3"D x 12-1/2"L totes available in both steel tray and poly case designs. Steel tote trays feature fold-down carry handles and four large storage compartments with adjustable dividers for carrying heavier loads. Poly tote cases offer a see-through lid with latches to prevent spilling, four large compartments and twelve adjustable dividers for sectioning. Trays and cases store in a 19-3/4"W x 20-1/8"H x 13-3/8"L modular rack that can be stacked or floor mounted for your particular storage demands.

Model	Description	Tote Style (Qty)
SPT-4	Combo Totes and Rack	Steel Trays (2) Poly Cases (2)
SPT-4P	Poly Totes and Rack	Poly Cases (4)
SPT-4S	Steel Totes and Rack	Steel Trays (4)
SPT-S	Additional Steel Tray	
SPT-P	Additional Poly Tote	

# LADDER RACKS



Ladder storage for all scenarios.

Whether you need the conventional top side ladder rack, the ability to store ladders inside or on the side of your trailer, Adrian Steel has a complete line of ladder racks you need to make the job easier.



A knowledgeable sales staff and certified installers are available to assist with your favorite Adrian Steel products to make your vehicle work ready!

Contact your preferred Adrian Steel Distributor today! To locate your local Adrian Steel Distributor visit [www.adriansteel.com](http://www.adriansteel.com).



Available in black or white



### SDL2T Side Mounted Ladder Rack

Access to your ladders is now easier than ever with Adrian's side mounted ladder rack. The SDL2T easily mounts to side of the cargo trailer and has the capability to carry two ladders. The rack can accommodate two ladders and features powder coated steel vertical bows, adjustable plastisol ladder clamps that protect the ladder while stowed. A tough nylon strap secures the ladders during transportation and the U-Bolts provide an attachment location to add a locking cable for security.

Note: The length of ladder the SDL2T can accommodate is determined by the length of the trailer.

Model	Description
SDL2T	Side Mounted Ladder Rack

### 2BRST Utility Racks

Carry ladders and more with confidence, 2BRST utility racks give you the flexibility no matter what the job.

- Welded tie hooks
- Universally designed to fit 6' to 8' wide trailers
- Available in a durable black or white powder coat finish
- Upright caps protect ladders when loading and unloading
- Available in 1 and 2 bar sets.

Note: 2BRST utility racks 1/2" or wider drip rails require TRDK Drip Rail Kit

Product	Model	Description
One Bar Steel	1BRST-W	Single Cross Beam Assembly/White
One Bar Steel	1BRST-B	Single Cross Beam Assembly/Black
Two Bar Steel	2BRST-W	Two Bar Assembly/White
Two Bar Steel	2BRST-B	Two Bar Assembly/Black
Drip Rail Kit	TRDK-B	Single Bar Kit/Black
Drip Rail Kit	TRDK-W	Single Bar Kit/White



### Ladder Keeper

Store ladders inside the trailer and off the floor with the LK8 Ladder Keeper. The Ladder Keeper features plastic coated clamps to protect the ladder rungs, a gas spring that compresses ladder rungs for secure transportation and an extruded track that simplifies loading and unloading the ladder. The Ladder Keeper will accommodate up to an eight-foot ladder in a 12' long trailer. Longer trailers can accommodate longer ladders with the option LKX extension that provides 4' of additional track. The Ladder Keeper requires roof bows in the trailer for installation.

Product	Model	Description
Ladder Keeper	LK8	Interior Ladder Rack
Extension	LKX	4' extension

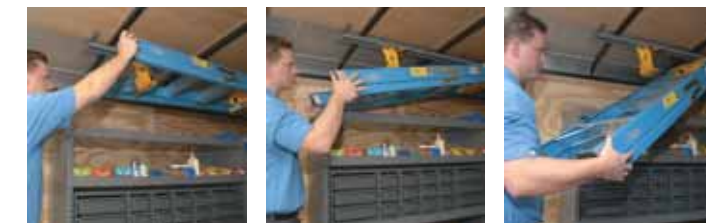

**1** Simply press ladder inward to release rear ladder rung from the rear clamp bracket.

**2** Walk the ladder back as the front clamp bracket glides on the track.

**3** Remove front rung from the front clamp bracket and you're ready to go to the job site!

# COMMERCIAL CARGO TRAILER EQUIPMENT

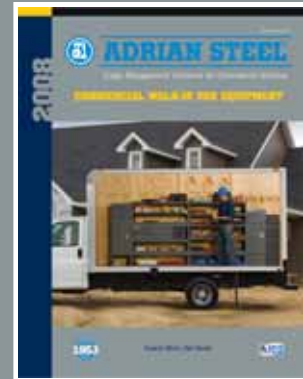
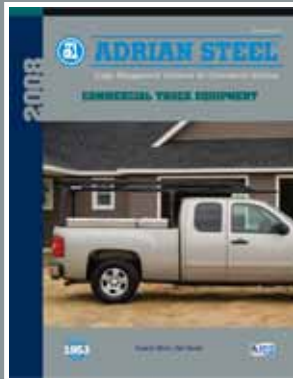
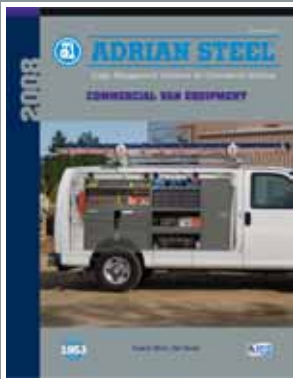

2008

Look for commercial truck and van catalogs from your Adrian Steel distributor or log onto [www.adriansteel.com](http://www.adriansteel.com)

**3 YEAR**  
**36,000 mile**  
**BEST WARRANTY**

Adrian Steel warrants its products to be free from defects in material and workmanship, under normal use and service for a period of three years or 36,000 miles, whichever first occurs, after the date of delivery to the original retail

purchaser, when installed by an authorized Adrian Steel Company distributor. Products purchased and not installed by authorized distributors will be warranted for a period of twelve months from the time of customer purchase.

CT43M0907

Distributed by



**ADRIAN STEEL®**

906 James Street, Adrian, Michigan 49221-3996  
517-265-6194 Fax: 517-265-5834  
Toll Free 800-677-2726 [www.adriansteel.com](http://www.adriansteel.com)  
[info@adriansteel.com](mailto:info@adriansteel.com)