

6036WX SPECIFICATIONS

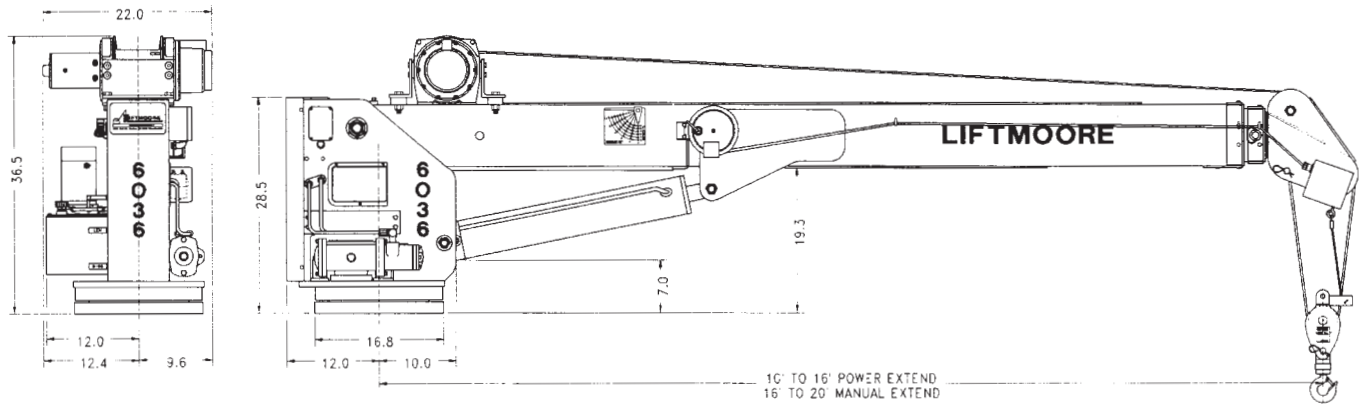

Moment Rating:

36,000 Ft.-Lb.

Lift Capacities:

6000 lbs. @ 6 ft.	2520 lbs. @ 14 ft.
4500 lbs. @ 8 ft.	2250 lbs. @ 16 ft.
3600 lbs. @ 10 ft.	2000 lbs. @ 18 ft.
3000 lbs. @ 12 ft.	1800 lbs. @ 20 ft.

Boom:

Standard length is 10 ft. to 16 ft. with power extension. An optional 4 ft. manual pull out extension to 20 ft. is offered. Powered extension booms include nylatron slide pads to reduce friction. An integrally mounted counterbalance valve is included with the cylinder for positive load holding. The boom angle varies from -5 to +75 degrees powered by a 4.5 in. diameter double acting hydraulic cylinder with counterbalance valve.

Hoist Winch:

The hoist winch is planetary gear driven for the most efficient operation in the industry. The winch is powered by a 2.5 HP 24 Volt DC series wound electric motor. Single line no load speed of the winch is 35 feet per minute. Winch drum to wire line ratio meets ANSI requirements.

Winch Wire Rope and Block:

1/4 in. Galvanized Aircraft Cable 85 ft. long (100 ft. on 20 ft. Boom) is supplied. Cable breaking strength is 7000 lbs. and conforms to ANSI requirements. A traveling block is supplied for use on single, double or triple line rigging. The block includes a roller thrust bearing swivel hook for easier rotation of the load.

Rotation:

A 45:1 worm gear speed reducer driven by a low speed, high torque hydraulic motor powers the crane's rotation. The 6036WX rotates on a gear bearing slewing ring. An electric swivel allows 360 degree continuous and unlimited rotation.

Power Source:

This crane operates on a 24 Volt DC operating system. An equalizer charger is included for charging with standard 12 Volt truck systems. Two 12 volt batteries (not supplied) for series operation are required. Group 31 deep cycle batteries are recommended for this purpose. A master cutoff switch, quick disconnect, circuit breaker and battery wire for standard truck installation are supplied.

Remote Pendant:

All powered functions are controlled by a remote pendant control that is 25 ft. long. The pendant control is removable from the crane. All switches used in the pendant are momentary contact type.

Load Sensor:

A load sensor is standard on the 6036WX. The load sensor will not allow hoist up, boom down or extension out when an overload is detected.

Anti Two-Block:

The 6036WX is supplied with an anti two-block device that prevents extending the boom against the traveling block. The anti two-block stops boom out, boom down and hoist winch up.

Mounting:

Four 7/8" Grade 8 bolts are required. Bolts are not included. The crane mounts on a 16-3/4 in. square base plate with a 14-3/4 in. square bolt pattern.

Weight:

6036WX-16 Actual 1500 lbs. 6036WX-20 Actual 1550 lbs.

Optional Accessories:

- Outrigger - Manual pull out, crank up/down
- Outrigger - Manual pull out, hydraulic up/down
- Pedestal
- Boom Rest
- Jack Stand



Up to 8000 lb. Capacity Cranes

Bulletin 446—8/98

LIFTMOORE, INC.

11505 Todd

Houston, Texas 77055

FAX (800) 824-5559 (USA & Canada)

FAX (713) 688-6324

(713) 688-5533