

**KNAPHEIDE**  
SINCE 1848

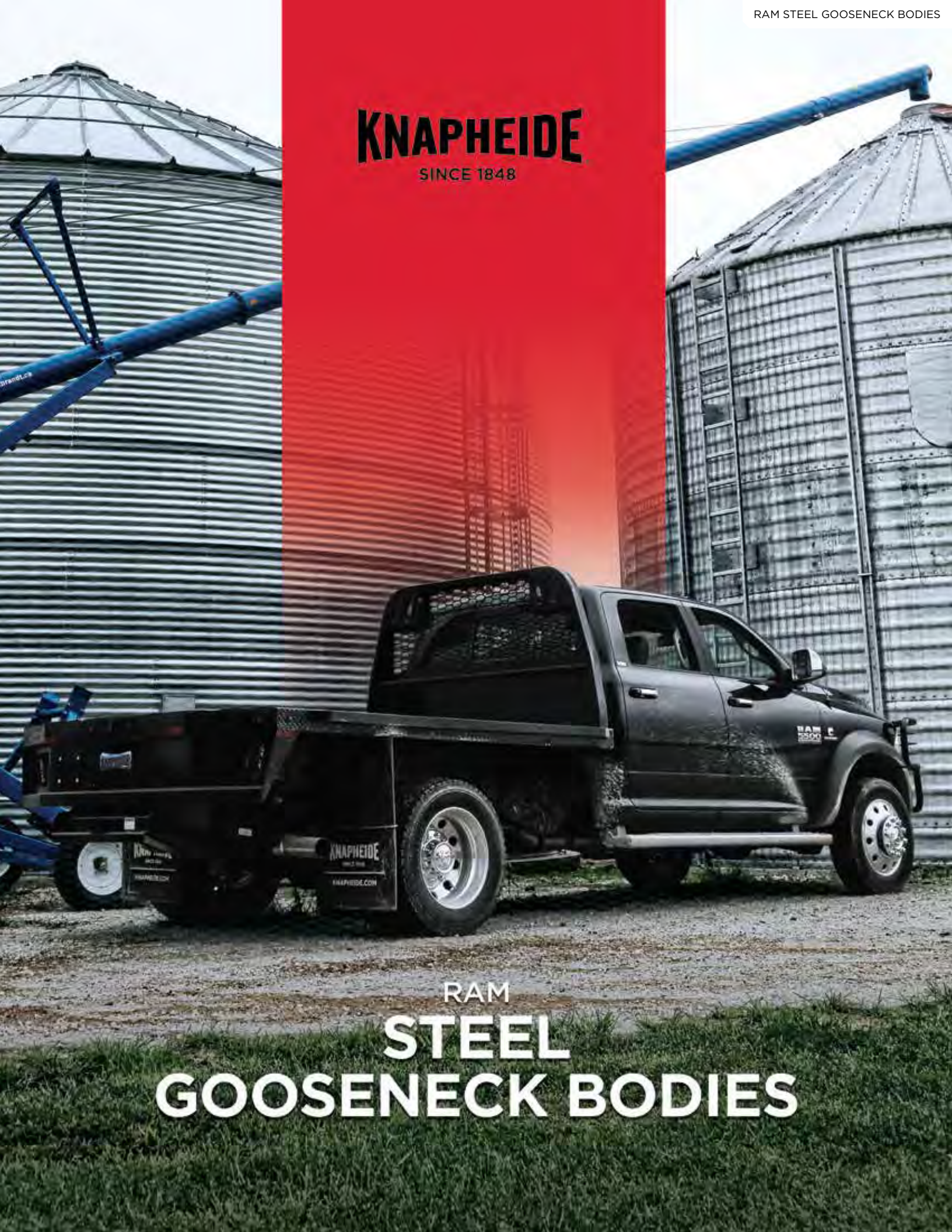

RAM  
**STEEL**  
**GOOSENECK BODIES**



# KNAPHEIDE STEEL GOOSENECK BODIES



## GOOSENECK TURNOVERBALL HITCH

A B&W Turnoverball®, rated at 30,000 lbs. gross trailer weight, with 7500 lb. tongue weight. Currently in our PGTB and PGTD models only.

## STEEL GOOSENECK BODIES

Versatility with storage solutions to meet every need, Knapheide Gooseneck Bodies are an easy choice. Rugged construction, enhanced styling and secure storage give you a body that can haul it all.

Reliable offerings range from the mid-level PGTB, skirted PGNC and the deluxe PGTD.

## POPULAR VOCATIONS



CONSTRUCTION



AGRICULTURE



LANDSCAPING/  
TREE CARE



OIL/MINING/GAS



# PGTB GOOSENECK BODIES



PGTB-116  
\*Body may be shown with optional features

- A. RUB RAILS**  
installed on both sides of bodies for strap, side and stake pocket protection
- B. RUGGED 1/8" THICK TREAD PLATE FLOOR**
- C. B&W TURNOVERBALL®**  
rated at 30,000 lbs. gross trailer weight, with 7500 lb. tongue weight
- D. BOLT ON RECEIVER HITCH -**  
Choose from 18K or 21K hitch, ordered separately to ship loose
- E. FORMED, INTEGRATED BULKHEAD**  
with stylized screened window and tapered design for improved visibility
- F. 7-WAY TRAILER PLUG**

- at rear of body
- G. DURABLE OVEN-CURED COAT**  
finish painted black
- H. ALL LED CLEARANCE AND MARKER LIGHTS**  
for visibility and added safety
- I. INTEGRATED OVAL LED B/U AND S/T/T LIGHTS**  
included in bulkhead and rear skirt

## FEATURES NOT SHOWN

12-GAUGE FORMED CROSS SILLS

**ELECTRODEPOSITION PRIME-PAINT SYSTEM**  
provides superior corrosion resistance

INTEGRATED DRIVER SIDE FUEL FILL CUP

# PGNC GOOSENECK BODIES



PGNC-116  
\*Body may be shown with optional features

- A. SKIRTED GOOSENECK STYLING**  
with integrated front and rear toolboxes
- B. RUB RAILS**  
installed on both sides of bodies for strap, side and stake pocket protection
- C. RUGGED 1/8" THICK TREAD PLATE FLOOR**  
with 6" structural channel long sills (4" on 8' models)
- D. HINGED ACCESS DOOR**  
to cover gooseneck hitch when not in use
- E. INTEGRATED CLASS V RECEIVER HITCH**  
rated at 18,000 lb.(optional on 8' bodies as most 56" CA chassis include a factory hitch)
- F. FORMED, INTEGRATED BULKHEAD**  
with stylized screened window and tapered design for improved visibility
- G. SAFETY CHAIN ATTACHMENT POINTS AND 7-WAY TRAILER PLUG**  
included in gooseneck box and at receiver hitch

- H. DURABLE OVEN-CURED COAT**  
finish painted black
- I. ALL LED CLEARANCE AND MARKER LIGHTS**  
for visibility and added safety
- J. INTEGRATED OVAL LED B/U AND S/T/T LIGHTS**  
included in bulkhead and rear skirt
- K. CONTINUOUS STAINLESS STEEL HINGES**  
are pry-proof and corrosion-resistant
- L. DOUBLE PANELED DOORS**  
consist of 20-gauge, two sided A-40 galvalume steel
- M. AUTOMOTIVE QUALITY, ROTARY-STYLE LATCHES**  
make opening and closing easy

## FEATURES NOT SHOWN

12-GAUGE FORMED CROSS SILLS

**ALUMINUM TREAD PLATE TRIM PIECE**  
on rear hitch plate provides a "no worry" step location

INTEGRATED DRIVER SIDE FUEL FILL CUP

**ELECTRODEPOSITION PRIME-PAINT SYSTEM**  
provides superior corrosion resistance

**INTERIOR COVER**  
protects internal latch from damage

**ADJUSTABLE SECURITY RING STRIKERS**  
provide a weather-tight seal

**NEOPRENE DOOR SEALS**  
protect compartments from the weather

**DOUBLE-SPRING OVER-CENTER DOOR RETAINER**  
eliminates involuntary door swing



# PGTD GOOSENECK BODIES



PGTD-114  
\*Body may be shown with optional features

**A. DOUBLE PANELED DOORS**  
consist of 20-gauge, two sided A-40 galvalneal steel

**B. FLIP TOP COMPARTMENTS**  
8" deep and with with exterior release latch. Flip tops utilize nitrogen gas struts for smooth opening and closing

**C. RUGGED 1/8" THICK TREAD PLATE FLOOR**

**D. 36" HIGH FRONT COMPARTMENTS**  
each with 250 lb. capacity shelves

**E. BOLT ON RECEIVER HITCH -**  
Choose from 18K or 21K hitch, ordered separately to ship loose

**F. FORMED, INTEGRATED BULKHEAD**  
with stylized screened window and tapered design for improved visibility

**G. 7-WAY TRAILER PLUG**  
at the rear of the body

**H. DURABLE OVEN-CURED COAT**  
finish painted black

**I. ALL LED CLEARANCE AND MARKER LIGHTS**  
for visibility and added safety

**J. UPGRADED REAR MOUNT LIGHTING SYSTEM**  
features LED S/T/T and B/U, LED strobe option\* with (8) selectable patterns, and built-in reflectivity for additional safety\*\*  
*\*Additional wire harness required for strobe lights  
\*\*Lights covered by 3-year limited warranty*

**K. CONTINUOUS STAINLESS STEEL HINGES**  
are pry-proof and corrosion-resistant

**L. AUTOMOTIVE QUALITY, ROTARY-STYLE LATCHES**  
make opening and closing easy

**M. FULL HEIGHT SLAM TAILGATE**  
with center mounted release handle

**N. B&W TURNOVERBALL®**  
rated at 30,000 lbs. gross trailer weight, with 7500 lb. tongue weight

**O. GALVANNEAL FENDERETTES**  
are welded on

**P. 7" DEEP REAR STEP**  
makes accessing cargo area safe and easy

## FEATURES NOT SHOWN

**12-GAUGE FORMED CROSS SILLS**  
3" formed

**250-LB. CAPACITY SHELVES MADE OF SPANGLED STEEL**  
(2 in each front vertical compartment)

**DOUBLE-SPRING OVER-CENTER DOOR RETAINER**  
eliminates involuntary door swing

**ELECTRODEPOSITION PRIME-PAINT SYSTEM**  
provides superior corrosion resistance

**INTERIOR COVER**  
protects internal latch from damage

**ADJUSTABLE SECURITY RING STRIKERS**  
provide a weather-tight seal

**NEOPRENE DOOR SEALS**  
protect compartments from the weather





# POPULAR OPTIONS

## PGTB / PGNC



**ROUGHNECK CONTRACTOR PACKAGE**

*Underbody toolboxes do not apply for PGTC*



**4" REMOVABLE SIDE BOARDS**



**ABOVE BODY AND UNDERBODY TOOLBOXES**

*Underbody toolboxes do not apply for PGTC*



**3/16" TREAD PLATE FLOOR**

**REQUEST A QUOTE**



Visit [knapheide.com/quote](https://knapheide.com/quote) and fill out the form to receive a quote and additional product information.







**REQUEST A QUOTE**



Visit [knapheide.com/quote](https://knapheide.com/quote) and fill out the form to receive a quote and additional product information.

## POPULAR OPTIONS

### PGTD



**3/16" TREAD PLATE FLOOR**



**ADDITIONAL ALUMINUM TREAD PLATE OVERLAY**

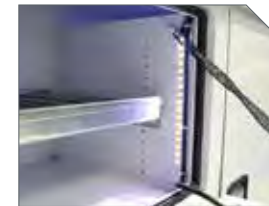

**LED COMPARTMENT LIGHTS**



**CARGO D-RINGS**



**C-TECH DRAWER SETS**



**POWER LOCKS**



# MODEL OPTIONS

## PGTB

MODEL	LENGTH	WIDTH	WEIGHT	APPLICATION	SWING RADIUS	LONG SILL SPACING
PGTB-708-R	7'0"	84"	726 lb.	36" CA SRW	59"	42"
PGTB-868-R	8'6"	84"	875 lb.	56" CA SRW	60"	42"
PGTB-968	9'6"	84"	927 lb.	60" CA SRW	67"	34"
PGTB-86-R	8'6"	96"	934 lb.	56" CA DRW	64.25"	42"
PGTB-96	9'6"	96"	989 lb.	60" CA DRW	70"	34"
PGTB-116	11'6"	96"	1,144 lb.	84" CA DRW	70"	34"

Standard models compatible with factory chassis-mounted gooseneck hitch.  
Gooseneck hitch may be ordered separately.

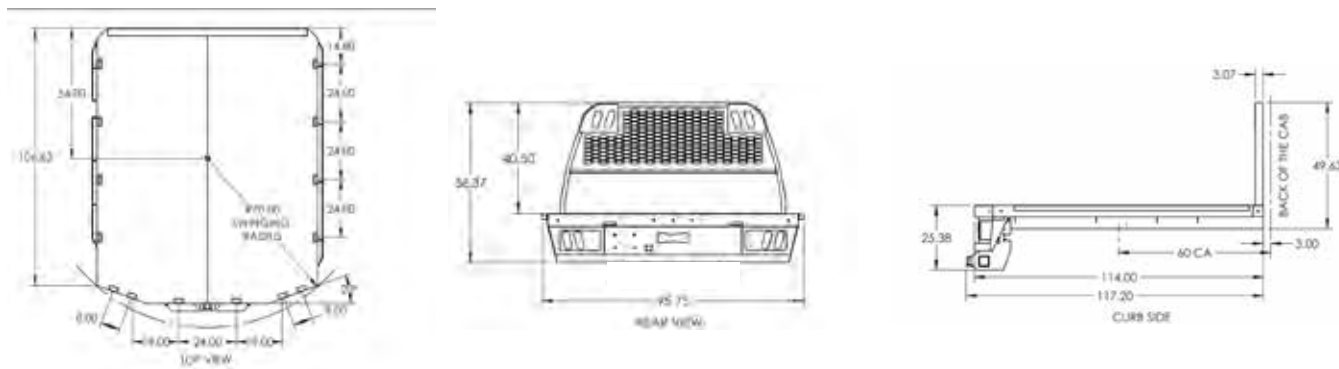

## PGTD

MODEL	LENGTH	WIDTH	WEIGHT	APPLICATION	SWING RADIUS	LONG SILL SPACING
PGTD-848-R	8'4"	80"	1,367 lb	56" CA SRW	61"	42"
PGTD-84-R	8'4"	96"	1,471 lb	56" CA DRW	63"	42"
PGTD-948	9'4"	80"	1,510 lb	60" CA SRW	72"	34"
PGTD-94	9'4"	96"	1,641 lb	60" CA DRW	72"	34"
PGTD-114	11'4"	96"	1,969 lb	84" CA DRW	72"	34"

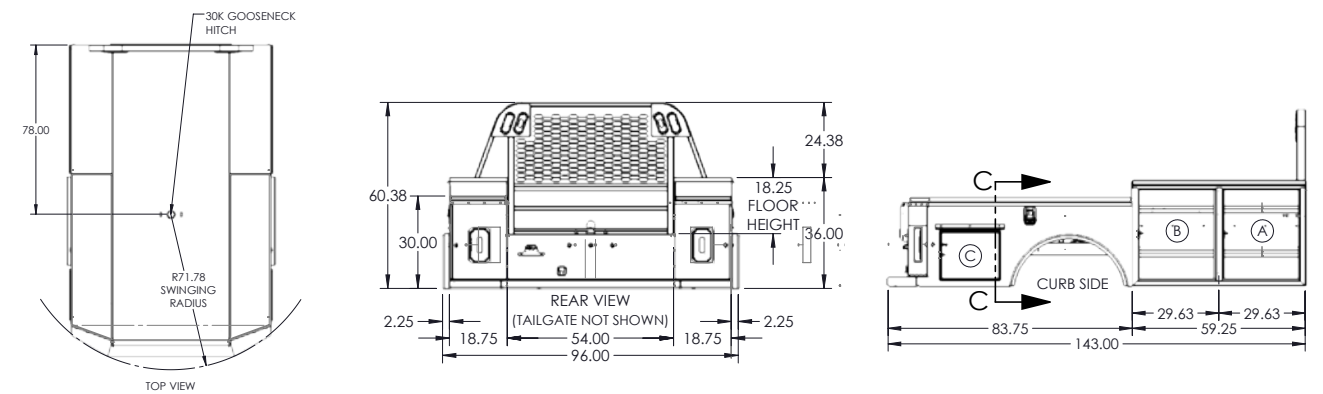

## PGNC

MODEL	LENGTH	WIDTH	WEIGHT	APPLICATION	SWING RADIUS	LONG SILL SPACING
PGNC-868-R	8'6"	84"	1,143 lb.	56" CA SRW	60"	42"
PGNC-968	9'6"	84"	1,283 lb.	60" CA SRW	67"	34"
PGNC-86-R	8'6"	96"	1,328 lb.	56" CA DRW	63"	42"
PGNC-96	9'6"	96"	1,411 lb.	60" CA DRW	70"	34"
PGNC-116	11'6"	96"	1,678 lb.	84" CA DRW	70"	34"

Standard models compatible with factory chassis-mounted gooseneck hitch.  
Gooseneck hitch may be ordered separately.

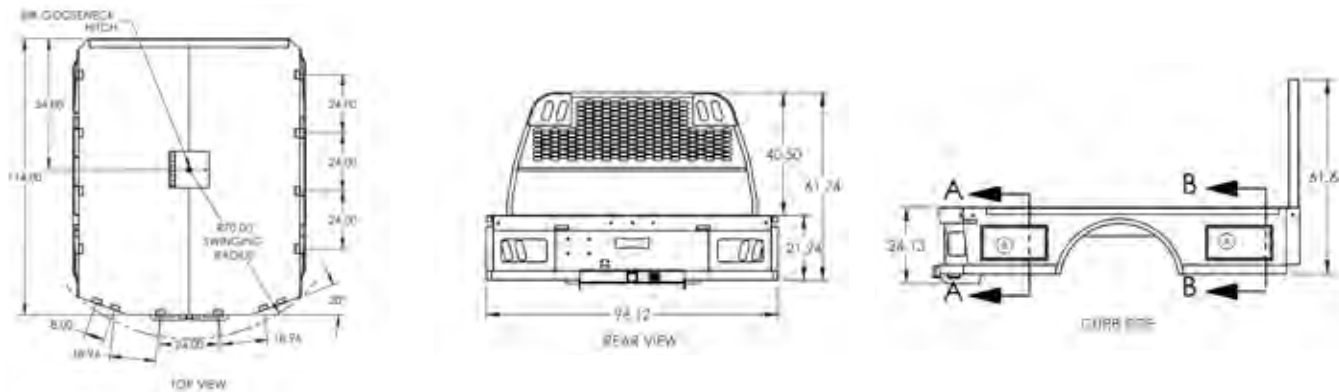

PGTB-96  
\*Body may be shown with optional features



# COMMITMENT TO CORROSION RESISTANCE

Corrosion won't be a concern when you buy quality Knapheide products. To give you the best corrosion protection, we utilize a state-of-the-art, custom-designed, 12-step, SST cathodic electrodeposition finishing system, called "E-Coat."

It bonds prime paint to steel by an electroplating process to give you a superior coat of primer, resulting in better corrosion protection compared to spraying methods.

This system allows us to create products with the highest level of corrosion resistance available.



FOLLOW US  
LIKE US  
TAG US



## THREE YEAR, LIMITED TIME WARRANTY



**NO RUST  
THROUGH**



**FREE FROM  
DEFECTS IN  
WORKMANSHIP**



**FREE FROM  
DEFECTS IN  
MATERIALS**

TO LEARN MORE VISIT  
[www.knapheide.com/warranty](http://www.knapheide.com/warranty)





# NEVER SETTLE

If you are going to be a leader, it takes more than building a high-quality product. It means never being totally satisfied with that product, no matter how high quality it may be. It requires constant vigilance and a willingness to take a chance on something new. And it means exceeding expectations every time. As the industry changes, one thing never will—our commitment to making customers like you as productive and efficient as possible. We know you don't settle, and we don't either. That's why we want you never to settle for anything less than Knapheide on the back of your truck.

**KNAPHEIDE. NEVER SETTLE.**



The Knapheide Manufacturing Company  
1848 Westphalia Strasse | Quincy, IL 62305  
**217-222-7131**  
[www.knapheide.com](http://www.knapheide.com)